

ME2S-2020-19U3M/C

MERCURY2 Super Series 20.2MP CMOS USB3.0 Area Scan Camera

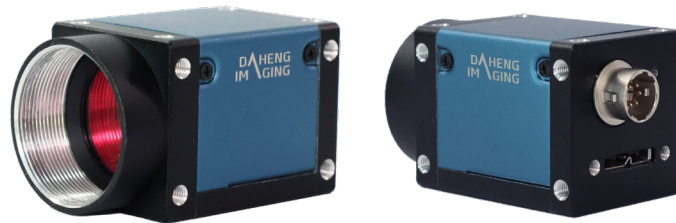

USBTM
VISION

GEN<i>i>CAM

CE

FC



The ME2S-2020-19U3M/C camera is a monochrome/color USB3.0 Vision camera with the Sony's latest 4th generation "Pregius S" CMOS sensor and higher performance FPGA. The ME2S-2020-19U3M/C camera has opto-isolated I/Os that adapt to specific needs. Four-side mounting holes provide maximum installation flexibility for ME2S-U3. Thanks to the extremely compact (29mm × 29mm), robust metal housings and locking screw connectors, the MERCURY2 Super cameras can secure the reliability of cameras deployed in harsh environments.

Applications

Suitable for machine vision applications such as industrial inspection, medical, scientific research, education, security and so on.

Features

- Trigger mode: Frame Start /Frame Burst Start
- Two exposure time modes: Standard exposure time mode / UltraShort exposure time mode
- Support Timed exposure mode and TriggerWidth exposure mode
- Acquisition Burst Mode
- Support Gamma, Binning, Decimation, Digital Shift, Black Level and Flat Field Correction
- Color models support Light source preset, Color Transformation Control and Saturation
- Monochrome models support Sharpness and Noise Reduction
- Programmable LUTs and storable user sets
- Support Timer and Counter
- Support Remove Parameter Limit to expand the range of exposure, gain, white balance, and so on
- 16KB data storage area for saving algorithm coefficients and parameter configuration

Specifications

Model	ME2S-2020-19U3C	ME2S-2020-19U3M
Resolution	4504(H) × 4504(V)	
Sensor	Sony IMX541, Global shutter CMOS	
Sensor Format	1.1"	
Pixel Size	2.74μm × 2.74μm	
Frame Rate	19.4fps	
ADC	12bit	
Pixel Bit Depth	8bit, 10bit, 12bit	
Mono/Color	Color	Mono
Pixel Formats	Bayer RG8 / Bayer RG10 / Bayer RG12	Mono8 / Mono10 / Mono12
SNR	40.6dB	42.1dB
Exposure Time	UltraShort: 1μs ~ 2.4μs; Standard: 3μs ~ 1s Actual Steps: 1 row period (decimation enabled/3μs~20μs), 1μs (>20μs)	
Gain	0dB ~ 24dB; Default: 0dB, Steps: 0.1dB	
Binning	1×1, 1×2, 1×4, 2×1, 2×2, 2×4, 4×1, 4×2, 4×4	
Decimation	Sensor: 1×1, 2×2	
Synchronization	Hardware trigger, software trigger	
Acquisition Mode	Single frame, Continuous, Software trigger, Hardware trigger	
Reverse X/Y	Reverse X/Y	
I/O Interface	1 input and 1 output with opto-isolated, 1 programmable GPIO	
Data Interface	USB3.0	
Power Supply	12VDC-10%~24VDC+10% supplied via the camera's 6-pin Hirose connector	
Power Consumption	4.8W @ 24VDC	
Operating Temp.	0°C ~ +45°C	
Storage Temp.	-20°C ~ +70°C	
Operating Humidity	10% ~ 80%	
Lens Mount	C	
Dimensions	29(W) × 29(H) × 38.8(L) mm	
Weight	60g	
Software	3rd-party software such as HALCON, MERLIC and LabVIEW	
OS	32bit / 64bit Windows, Linux, Android, ARMv7, ARMv8	
Conformity	CE, RoHS, FCC, GenICam™, USB3.0 Vision®	

I/O Interface

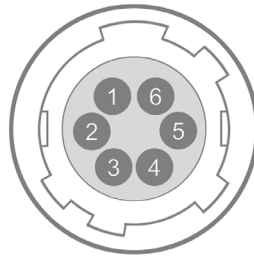

Pin	Definition	Description
1	POWER_IN	Camera external power, +12V DC(-10%)~+24V DC(+10%)
2	Line0+	Opto-isolated input +
3	Line2	GPIO input/output
4	Line1+	Opto-isolated output +
5	Line0-/Line1-	Line0-: Opto-isolated input - Line1-: Opto-isolated output -
6	GND	PWR GND & GPIO GND

Spectral Response

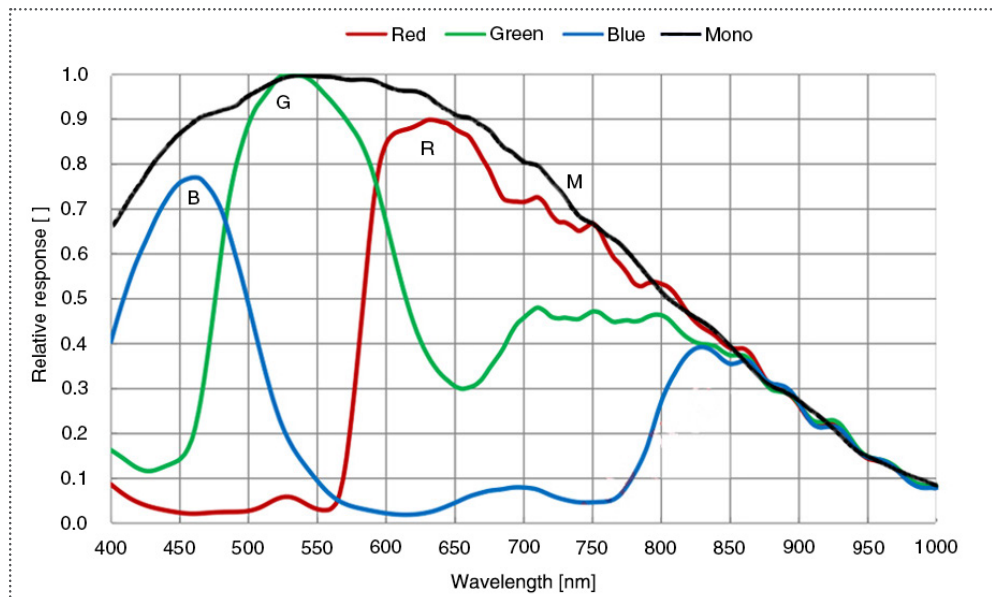

ME2S-2020-19U3M/C

Technical Drawing

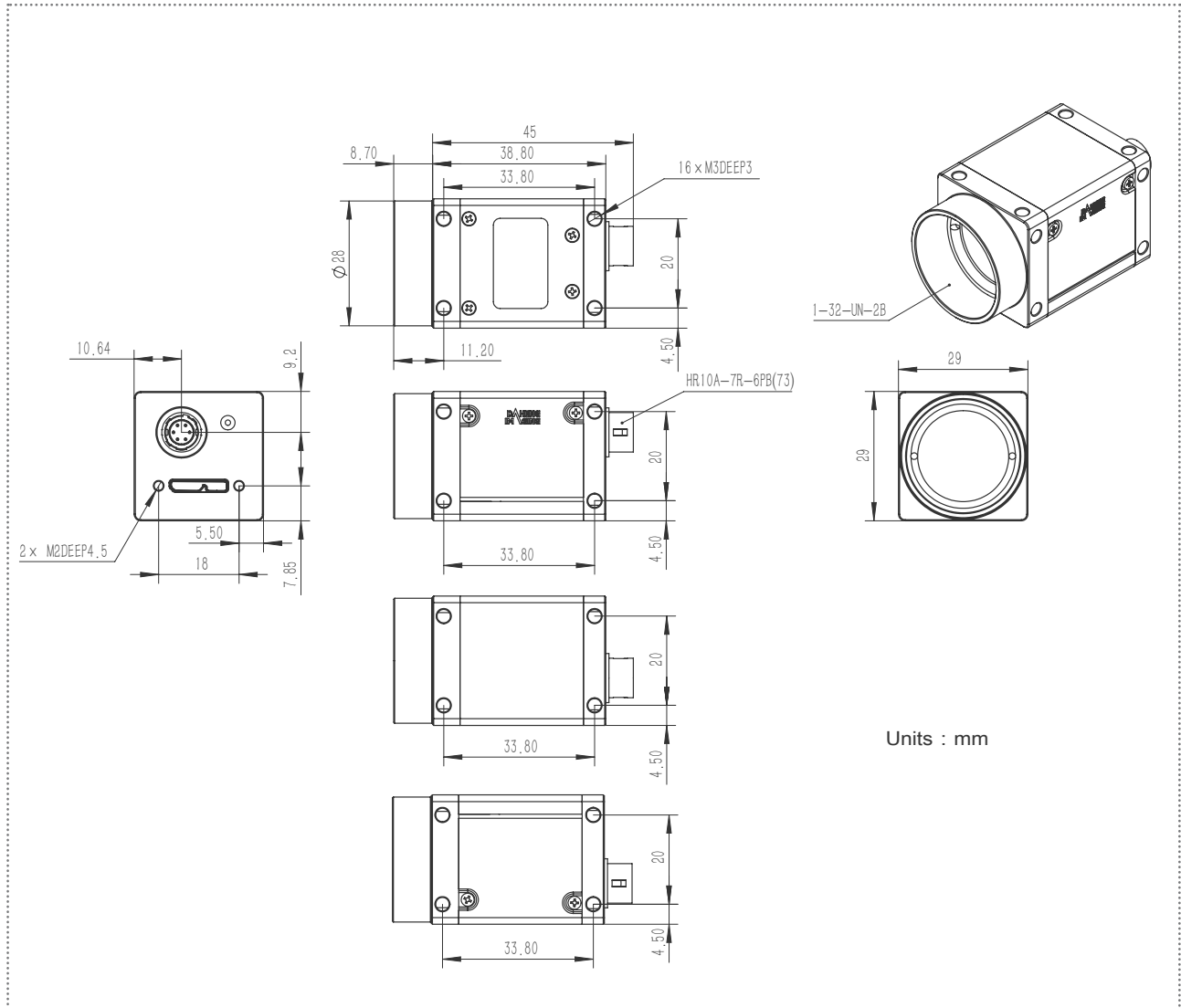

China Daheng Group, Inc. Beijing Image Vision Technology Branch

12F Daheng Science & Technology Tower, No.3 Suzhou Street, Haidian District, Beijing China, 100080

Tel: +86 10 82828878

E-mail: isales@daheng-imaging.com