

MERCURY2 PRO SERIES

ME2P-2621-15U3M/C



- Ultra small, light and robust
- 1.1" global shutter CMOS sensor
- Compatible with GenICam™ and USB3 Vision®
- USB3.0 interface
- 26.2 Megapixels
- High definition and low cost

The MERCURY2 PRO USB3.0 series (ME2P-U3) camera is DAHENG IMAGING's high definition industrial digital camera. ME2P-2621-15U3M/C supports Gamma, Reverse, Black Level, Flat Field Correction and more features to adapt to various vision applications, especially supporting Sharpness and Noise Reduction to improve the image quality.

ME2P-2621-15U3M/C is a monochrome/color USB3 Vision camera with the GMAX0505 CMOS sensor. The ME2P-2621-15U3M/C camera has opto-isolated I/Os that adapt to specific needs. Four-side mounting holes provide maximum installation flexibility for ME2P-U3. Thanks to the extremely compact design (36mm × 31mm × 38.8mm), locking screw connectors, the MERCURY2 PRO series cameras can secure the reliability of cameras deployed in harsh environments.

Featuring compact design, outstanding performance, ease of installation and use, the MERCURY2 PRO cameras are especially suitable for machine vision applications such as industrial inspection, medical, scientific research, education, security and so on.

Features

- Programmable ROI, increased frame rate with partial scan
- Gain, exposure and white balance programmable (white balance only for color models)
- Support auto gain, auto exposure and auto white balance (auto white balance only for color models)
- Four acquisition controls: Single frame acquisition/Continuous acquisition/Software trigger acquisition/External trigger acquisition
- Trigger mode: Frame Start /Frame Burst Start
- Support LUTs, storable user sets, Timer and Counter
- Support Reverse X/Y, Black Level, Static Defect Correction and Flat Field Correction
- Support Binning, Decimation, Gamma, Digital Shift
- Monochrome models support Sharpness and Noise Reduction
- Color models support Light source preset, Color Transformation Control and Saturation
- Support Remove Parameter Limit to expand the range of exposure, gain, white balance, and so on
- 16KB data storage area for saving algorithm coefficients, parameter configuration, and so on
- Compatible with GenICam™ and USB3 Vision®, can be used in a wide range of 3rd-party software such as HALCON, MERLIC and LabVIEW directly
- Optimized software package for 32/64bit Windows, and support Linux, Android, ARMv7 and ARMv8
- Multiple samples and easy-to-integrate SDKs for various programming tools
- Regulations: CE, RoHS, GenICam, USB3 Vision

Performance Specifications

Model	ME2P-2621-15U3M/C
Interface	USB3.0
Resolution	5120(H) × 5120(V)
Frame rate	15.1 fps @5120 × 5120
Sensor	1.1", global shutter GMAX0505 CMOS
Pixel size	2.5 μm × 2.5 μm
Pixel Bit Depth	8bit, 12bit
Spectrum	Monochrome / Color
Exposure time	11μs ~ 1s

Mechanical Specifications

Weight	66g
Dimensions	36(W)×31(H)×38.8(L) mm, w/o connectors

Technical Drawing

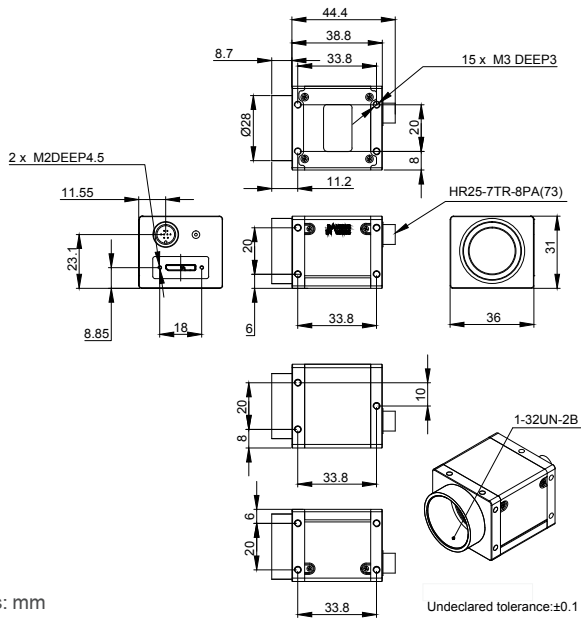

Units: mm

Electrical Specifications

Power requirement	5 VDC via USB cable
I/Os	1 input / 1 output, 2 GPIOs
Data interface	Micro B
Power consumption	<3.5W @5V DC

Environmental Specifications

Operating temp.	0°C ~ +45°C
Storage temp.	-20°C ~ +70°C
Operating humidity	10% ~ 80%

Optical Specifications

Lens mount	C-Mount (standard), CS-Mount (optional)
------------	---

Spectral Response

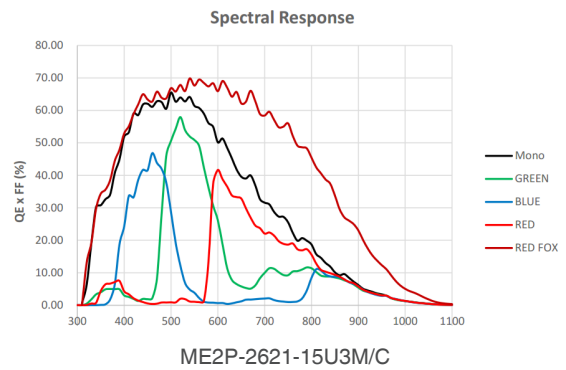

China Daheng Group, Inc. Beijing Image Vision Technology Branch

12F Daheng Science & Technology Tower, No.3 Suzhou Street, Haidian District,
Beijing China, 100080

Tel: +86 10 82828878

E-mail: isales@daheng-imaging.com

For more information please visit : www.daheng-imaging.com/en

Specifications are subject to change without prior notice.

Copyright © 2022 China Daheng Group, Inc. Beijing Image Vision Technology Branch. All rights reserved.

May 20, 2022