



User's Manual

Line Scan Camera

Type : RMSL2K53GE



NIPPON ELECTRO-SENSORY DEVICES CORPORATION

GigE Vision is a registered trademark of AIA

For Customers in the U.S.A.

This equipment has been tested and found to comply with the limits for a Class A digital device, in accordance with Part 15 of the FCC Rules. These limits are designed to provide reasonable protection against harmful interference when the equipment is operated in a commercial environment. This equipment generates, uses, and can radiate radio frequency energy and, if not installed and used in accordance with the instruction manual, may cause harmful interference to radio communications. Operation of this equipment in a residential area is likely to cause harmful interference, in which case the user will be required to correct the interference at his or her own expense.

For Customers in the EU

This equipment has been tested and found to comply with the essential requirements of the EMC Directive 2004/108/EC, based on the following specifications applied:

EU Harmonised Standards

EN55032:2015 Class A

EN55032:2012 Class A

EN55011:2009+A1:2010 Class A

EN61000-6-2:2005

Directive on Waste Electrical and Electronic Equipment (WEEE)



Please return all End of Life NED products to the distributor from whom the product was purchased for adequate recycling and / or disposal. All costs of returning the Product to NED are borne by the shipper.

Introduction

Thank you for purchasing NED's Line Scan Camera. We look forward to your continued custom in the future.

For safety use

- ◆ For your protection, please read these safety instructions completely before operating the product and keep this manual for future reference.
- ◆ The following symbols appear next to important information regarding safe product handling.

 Warning	If the product is not handled properly, this may result in serious injury or possible death.
 Caution	If the product is not handled properly, this may result in physical injury or cause property damage.

Safety precaution

Warning

- ◆ Never disassemble or modify this product, unless otherwise specified to do so in this manual.
- ◆ When hands are wet, avoid handling this product and do not touch any of the connection cable pins or other metallic components.
- ◆ Do not operate this product in an environment that is exposed to rain or other severe external elements, hazardous gases or chemicals.
- ◆ If the product is not to be used for an extended period of time, as a safety precaution, always unplug the connection cable from the camera unit.
- ◆ If the product installation or inspection must be executed in an overhead location, please take the necessary measures to prevent the camera unit and its components from accidentally falling to the ground.
- ◆ If smoke, an abnormal odor or strange noise is emitted from the camera unit, first turn OFF power, then unplug the cable from the camera unit.
- ◆ This product is not intended for use in a system configuration built for critical applications.

Instructions before use

- ◆ Only operate this product within the recommended environmental temperature range.
- ◆ Use only the specified power source and voltage rating.
- ◆ Do not drop this product. Avoid exposure to strong impact and vibrations.
- ◆ Install the camera unit in a well-ventilated environment, in order to prevent the camera from overheating.
- ◆ If the camera must be installed in an environment containing dust or other particles, take required measures to protect the camera unit from dust adhesion.
- ◆ Do not unplug the cable while power is being supplied to the camera unit. To prevent product damage, always shut down the power supply before unplugging the power cable.
- ◆ When the surface of the camera window becomes dirty due to dust or grime, black smudges appear in the displayed image. Use an air blower to remove the dust particles. Dip a cotton swab into ethanol alcohol and clean the camera window. Be careful not to scratch the glass.
- ◆ Use of non-infrared lighting such as a fluorescent lamp is recommended. If halogen lighting is employed, always install an infrared filter into your system configuration.
- ◆ Note that exposure to long wavelength light outside of the sensors visible optical range can affect the image.
- ◆ Sensitivity may fluctuate depending on the spectral response level of the light source. In cases like this, changing the light source to one with a different spectral response level may reduce this problem. Moreover, this irregular sensitivity can be completely lost by using 4.8 pixel correction function. Please refer to 4.8 pixel correction function for details.
- ◆ Note that when the sensor is exposed to excessive quantities of light, blooming may occur, because this product does not have a special Anti-Blooming function.
- ◆ For stabilized image capturing, turn on the power supply and execute aging for ten to twenty minutes before actually using the camera unit.
- ◆ Do not share the power supply with motor units or other devices that generate noise interference.
- ◆ Do not disconnect the camera while rewriting the embedded memory.
- ◆ When you change the exposure mode that is set at the NED factory, input control signal (CC1) from the capture board.
- ◆ SG (Signal Ground) and FG (Frame Ground) are connected inside the camera. Please install your system such that a loop is not created by the GND potential difference.

Product Warranty

Warranty Period

- ◆ The product warranty period, as a general rule, is two years from purchase; however for detailed conditions please contact the sales representative for your region/country.
- ◆ However, in some cases due to the usage environment, usage conditions and/or frequency of use, this warranty period may not be applicable.

Warranty Scope

- ◆ Product repair will be performed on a Return To Manufacturer basis. On-site maintenance will incur additional charges.
- ◆ If defects in material or workmanship occur during the warranty period, the faulty part will be replaced or repaired by us free of charge. Return shipping charges must be paid by the sender. However, the following cases fall outside of the scope of this warranty:
- ◆ The expired date of the warranty period on the product repaired or replaced during the warranty period of the original product is the same as the expired date of the warranty period on the original product.

Exclusions from Warranty Coverage

- ◆ We will under no circumstances assume responsibility for the following cases: damage caused by fire, earthquake, other acts of a third party, other accidents, negligent or intentional misuse by the user, or other usage under extraordinary circumstances.
- ◆ Damages (e.g. loss of business profits, business interruption, etc.) resulting from use or non-use.
- ◆ Damages caused by use other than as described in this document.
- ◆ Damages resulting from malfunction due to a connected device.
- ◆ Damages resulting from repairs or modifications performed by the customer.

Fault Diagnosis

- ◆ As a general rule, in the first instance fault diagnosis should take the form of a telephone call or an email to enable us to assess the circumstances of the malfunction.
- ◆ However, depending on the customer's requests, we, or our agent, may require an additional fee for this service.

Exclusion of Liability for Compensation for Missed Opportunities

- ◆ Regardless of whether within the warranty period or not, our warranty does not cover compensation for missed opportunities for our customers, or our customers' customers, caused by a fault of our products, nor for damage to products other than our own, or related business.

Note about Product Usage

- ◆ This product has been designed and manufactured as a general-purpose product for general industry. In applications expected to be life-critical or safety-critical, the installer or user is requested to install double or triple failsafe systems.

Repair Service Outline

- ◆ The cost of dispatching engineers etc. for repair service is not included in the price of purchased and supplied goods. On request, arrangements can be made separately.

Scope of Repair Service

- ◆ The above assumes business dealings and usage to take place in the customer's region / country. In cases of business dealings and/or usage outside the customer's region/country, separate consultation is required.

Table of Contents

1 Product Outline	10
1.1 Features.....	10
1.2 Applications	10
1.3 Performance Specifications	12
2 Camera Setting and Optical Interface	14
2.1 Setting Camera	14
2.2 Fixing Camera.....	14
2.3 Optical Interface	16
3 Hardware	17
3.1 Camera Connection	17
3.2 Input / Output Connectors and Indicator	19
3.3 Power Supply Connection.....	20
3.4 External Trigger Connector (HR10G-10R-12PB)	21
3.4.1 RS-422 Input.....	22
3.4.2 LVDS Input.....	22
3.4.3 TTL Input.....	23
3.4.4 RS-422 Output.....	23
3.4.5 LVDS Output.....	24
3.4.6 TTL Output.....	24
3.4.7 Relation of External Trigger Input and Output	25
3.5 RJ-45 Connector.....	26
3.6 LED indicating camera status.....	26
4 Camera Control	27
4.1 Flow of Camera Control.....	27
4.1.1 GenICam overview	27
4.1.2 List of Camera Control Registers	27
4.2 Details on register system.....	32
4.2.1 Category.....	32
4.2.2 Device Control.....	33
4.2.2.1 Displaying Temperature of Camera.....	33
4.2.3 Image Format Control.....	34
4.2.3.1 OffsetX and Width Settings	34

4.2.3.2	Height Setting	35
4.2.3.3	Scan Direction	36
4.2.3.4	Pixel Format Setting.....	36
4.2.3.5	Test Pattern	37
4.2.4	Acquisition Control.....	40
4.2.4.1	Setting Line Rate	40
4.2.4.2	Setting Trigger Selector	41
4.2.4.3	Setting Permission for using External Trigger	42
4.2.4.4	Setting Exposure Mode	42
4.2.4.5	Setting Exposure Time	43
4.2.5	Analog Control	43
4.2.5.1	Setting Analog gain	43
4.2.5.2	Setting Digital gain	44
4.2.5.3	Setting Offset	44
4.2.6	Digital IO Control.....	45
4.2.6.1	Setting I/O signal	45
4.2.6.2	Setting Line Mode	45
4.2.6.3	Setting Input Signal Polarity Reversal	45
4.2.6.4	Setting Line Source.....	46
4.2.6.5	Setting I/O Signal Format	46
4.2.6.6	Setting External Line Trigger Chattering Prevention	47
4.2.7	Encoder Control.....	48
4.2.7.1	Setting Encoder Control.....	48
4.2.7.2	Setting Input Signal for Encoder Source A	48
4.2.7.3	Setting Input Signal for Encoder Source B	49
4.2.7.4	Setting Encoder Mode	50
4.2.7.5	Setting Encoder Divider	50
4.2.7.6	Setting Encoder Output Mode	51
4.2.7.7	Setting Encoder Status.....	51
4.2.7.8	Setting Time of Encoder Timeout.....	51
4.2.7.9	Setting Encoder Reset Signal	52
4.2.7.10	Setting Encoder Reset Activation	52
4.2.8	User Set Control.....	53
4.2.8.1	Setting Memory Selection	53
4.2.8.2	Setting Memory Loading	53
4.2.8.3	Setting Memory Saving.....	53
4.2.8.4	Resetting Factory camera setting	54
4.2.9	Transport Layer Control.....	55

4.2.9.1	Setting Persistent IP	55
4.2.10.1	Setting Pixel Correction	58
4.2.10.2	Setting Pixel Correction Target Value	58
4.2.10.3	Saving White Pixel Correction Data	59
4.2.10.4	Saving Black Pixel Correction Data	59
4.2.10.5	Setting conditions of White pixel correction and Black correction	59
4.3	Setting Procedure of External Trigger Settings (for Examples).....	60
4.3.1	One-phase Trigger setting (for Example).....	60
4.3.2	Two-phase Trigger setting (for Example).....	61
4.4	Calculating the Maximum Value of Packet Delay	63
4.6	Exposure Mode and Timing	64
4.6.1	Free run Exposure Mode	64
4.6.2	External Trigger (Timed) Exposure Mode	65
4.6.3	External Trigger (TriggerWidth) Exposure Mode	66
4.7	Setting Offset	67
4.8	Setting Gain	68
4.9	Pixel Correction	70
5	Basic Camera Setting Checks	71
5.1	Before Power On	71
5.2	After Power On	71
6	Sensor Handling Instructions	72
6.1	Electrostatic Discharge and the Sensor	72
6.2	Protecting Against Dust, Oil and Scratches.....	72
6.3	Cleaning the Sensor Window.....	72
7	Troubleshooting	73
7.1	No Image	73
7.2	Noise on Image.....	75
7.3	Camera becomes hot.....	76
8	Others.....	77
8.1	Notice.....	77
8.2	Contact for support.....	77
8.3	Product Support.....	78
	Revision History	79

1 Product Outline

1.1 Features

- High speed readout : 53.1kHz
- Easy control of gain / offset / video output with external software
- GigE Vision® external interface for easy connection between camera and PC
- Data transmission up to 100m using a CAT-5e cable or above
- Single power source DC12~15V for operation
- Pixel non-linearity / shading correcting function

1.2 Applications

- Inspection of transparent panels and PCBs
- Inspection of high speed moving objects
- Flat panel display inspection
- Inspection of glass and sheet-like objects
- Printed circuit board inspection
- This camera utilizes an Intelligent Transportation System
- Outdoor surveillance

An example of visual inspection of metallic parts is shown below.

- Example using one camera.
(Inspection of surface)

- Example using three cameras.
(Inspection of surface and end faces)

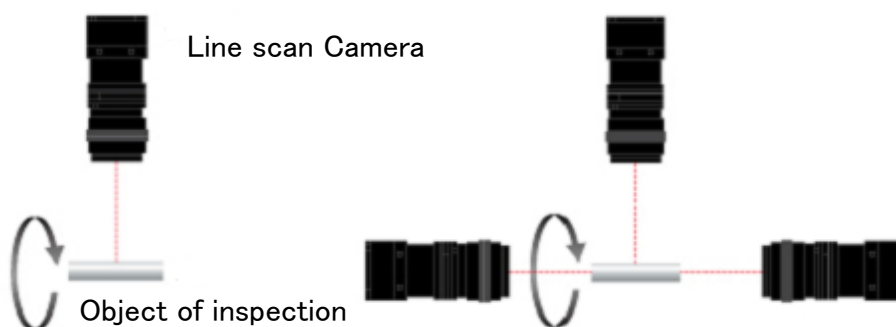

Figure 1-2-1 Visual Inspection of Metallic Cylinder

Object of inspection (example)

Metallic parts with cylindrical/conical shapes (surface and roller end faces)

- Automobile component
- Architectural reinforcement parts
- Various pin parts

Typical detection item

- Chip
- Dent
- Scratch
- Chipped end faces
- External dimensions

Device specification

1. Camera: 2048 pixel Line scan camera
2. Controller: Dedicated software for PC system

1.3 Performance Specifications

The Performance Specifications are shown below. The data is shown when the camera is operating at the maximum scan rate, unless otherwise specified.

Table 1-3-1 Performance Specifications

Items		Specifications	
		RMSL2K53GE	
Number of Pixels		2048	
Pixel Size H x V (μm)		14 x 14	
Sensor Length (mm)		28.672	
Data Rate (MHz)		125	
Scan Rate [kHz]/ (μs)		Mono8	53.1 / (18.8)
		Mono10	28 / (35.6)
		Mono10 packed	37.4 / (26.7)
Responsivity (V/ [lx·s]) (typically) [Minimum Gain, Pixel Correction Initial Value]		100 * Visible Area (400~700nm) Analog 5V Conversion Sensitivity/	
Gain Adjustable Range Analog Amplifier +Digital		Analog Amplifier : x 1 ~ x 10 (8 STEP) Digital : x 1 ~ x 2 (512 STEP)	
Digital Offset Adjustable Range (DN)		8bit : -127~127(0.5DN/STEP)	
FPN (Fixed Pattern Noise)		Typically 5%(without correction, at minimum gain) 2%(with correction, at minimum gain)	
PRNU (Photo Response Non Uniformity)		Typically 8%(without correction, at minimum gain) 4%(with correction, at minimum gain)	
Random Noise		Typically 10DN (peak value, at minimum gain)	
Video output format		GigE	
Control Input		Line In1~3: Exposure trigger, Frame trigger or Encoder signal	
Connectors	Data/Controller	RJ45	
	Power Supply	Hirose: HR10A (6Pin)	
	External Trigger	Hirose: HR10A (12Pin)	
Lens Mount		Nikon F Mount	
Operating Temperature (°C) No Condensation		0 ~ 50	
Power Supply Voltage (V)		DC12 ~ 15[±5%]	
Consumption Current (mA) * typically		580	
Size W x H x D (mm)		60x100x83.3 (F Mount)	

Mass (g) (Camera only)	455 (F Mount)
Additional Functions	1. Shading Correction 2. Gain/Offset /Video Output Control 3. Programmable Exposure Control 4. Scan Direction Switching 5. Test Pattern Output 6. Two-phase Trigger

Remarks: 1) DN : Digital Number (8bit : 0 -255 / 10bit : 0 -1023)
 2) Measurements were made at room temperature

The spectral Responsivity is shown below.

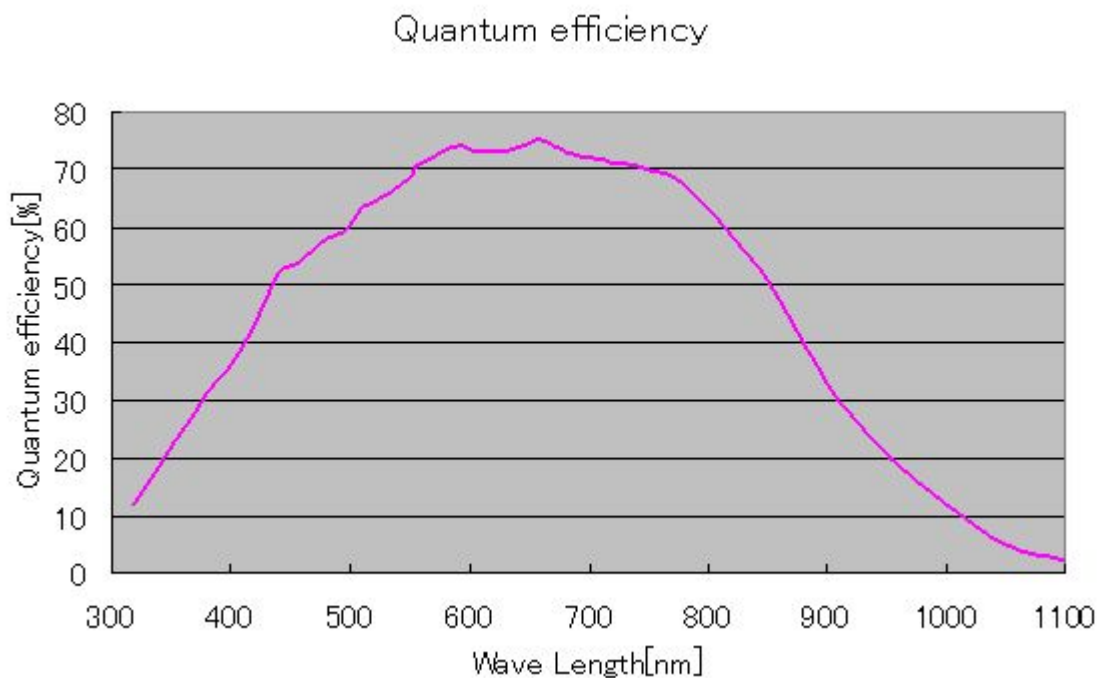

Figure 1-3-1 Spectral Responsivity

2 Camera Setting and Optical Interface

2.1 Setting Camera

Use the M4 screw holes or the screw hole for a tripod to set the camera.

2.2 Fixing Camera

Use the M4 screw holes (4 places at the front, 8 places at the side) to fix the camera. Or use the 1/4"-20UNC screw hole (the screw hole for a tripod, 1 place at the side) to fix the camera.

If using the front panel M4 mounting holes, the screw length for fixing the camera should be less than 6mm.

No X-, Y-axis orientation and tilt adjustment mechanism is available. Please provide an adjustment mechanism yourself as necessary.

The dimensions for camera are shown below.

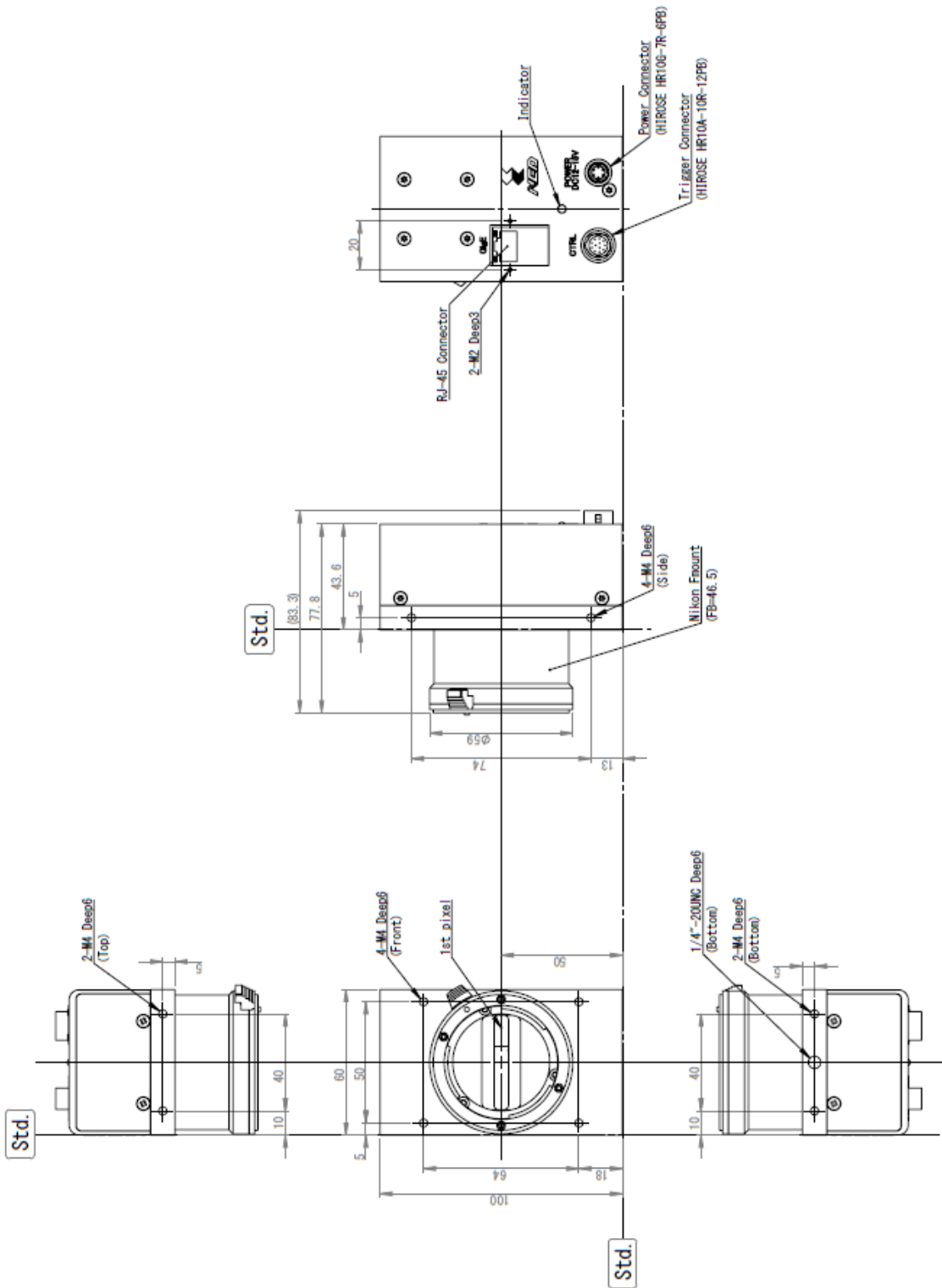

2.3 Optical Interface

The amount and wavelengths of light required to capture useful images depend on the intended use. Factors include the property, speed, the object's spectral characteristics, exposure time, the light source characteristics, the specifications of the acquisition system and so on.

The exposure amount (exposure time x light amount) is the most important factor in getting desirable images. Please determine the exposure amount after studying what is most important to your system.

Keep these guidelines in mind when setting up your light source:

- LED light sources are relatively inexpensive, provide a uniform field and longer life span compared to other light sources. However, they also require a camera with excellent sensitivity.
- Halogen light sources generally provide very little blue relative to infrared light (IR).
- Fiber-optic light distribution systems generally transmit very little blue light relative to IR.
- Metal halide light sources are very bright but have a shorter life span compared to other light sources.

Generally speaking, the brighter light sources, shorter life span.

CMOS image sensors are sensitive to infrared (IR). We recommend using daylight color fluorescent lamps that have low IR emissions. If you use a halogen light source, to prevent infrared from distorting the images use an IR cutoff filter that does not transmit IR wavelengths.

3 Hardware

3.1 Camera Connection

Use the camera in the following way:

1. Connect the camera to the PC with a LAN cable.

Notes:

- 1) Use a CAT-5e or higher grade LAN cable to connect the camera to the PC.
- 2) In countries requiring CE certification, use a shielded cable.
- 3) Use a Gigabit Ethernet compatible LAN port.

To add additional cameras use a NIC (Intel: Gigabit CT Desktop Adapter EXPI9301CT etc.) on the PCI or PCI-Express bus.

2. Connect the power to the camera.

Note:

Use a power cable to connect the camera power to the camera. Connect the plug end of the cable to the camera, and the open end to the power supply. In addition, a lens, lens mount, illumination, trigger controller, etc. may be required. Please choose equipment suitable for your application's requirements.

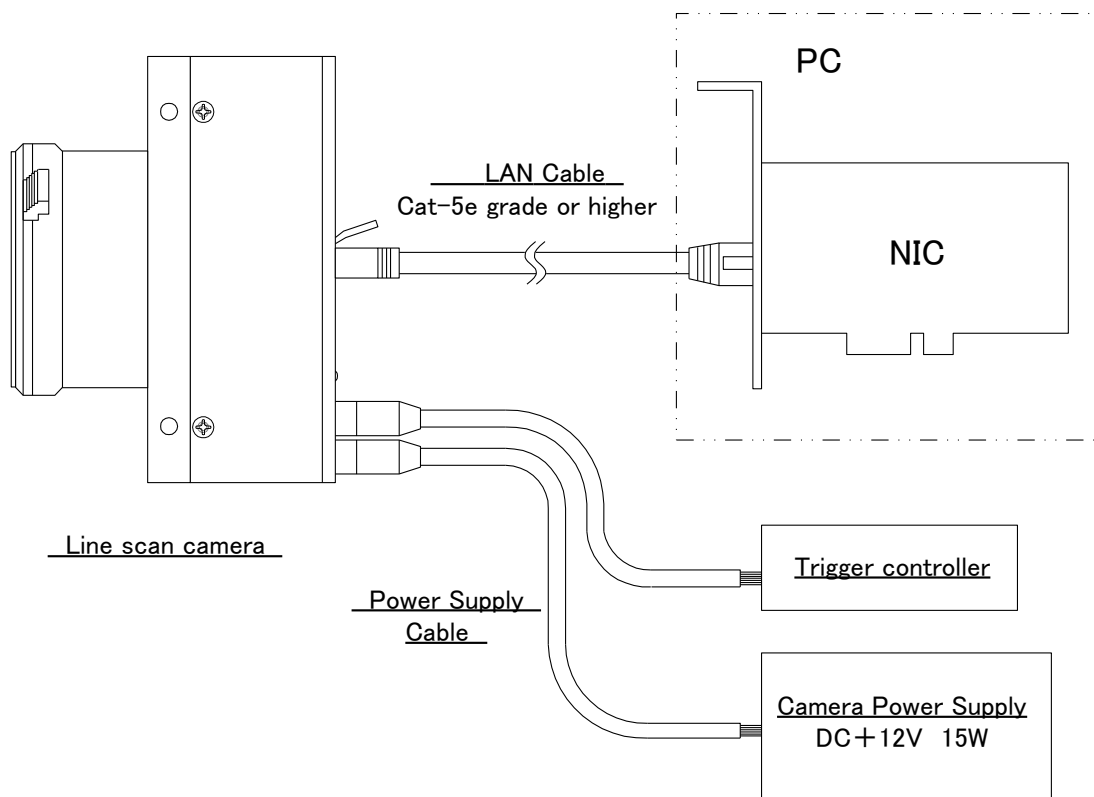
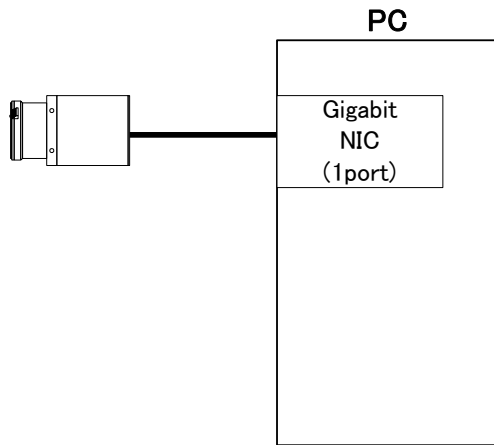
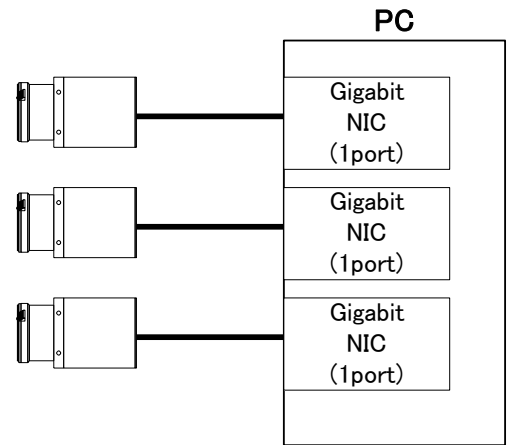

Figure 3-1-1 Connections between Camera and PC etc.

Example of connection between
1 PC and 1 camera



Example of connection between
1 PC and 3 cameras



Example of connection between
1 PC and 3 cameras

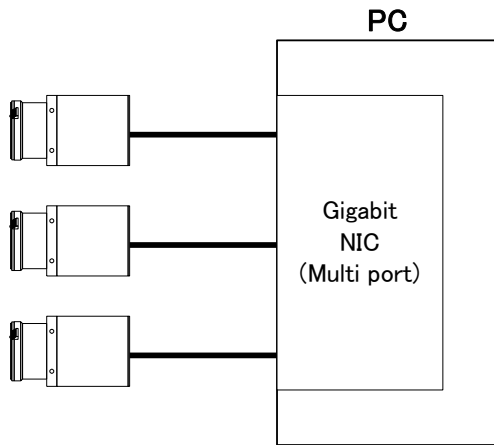

Example of connection between
of 1 PC and 3 cameras

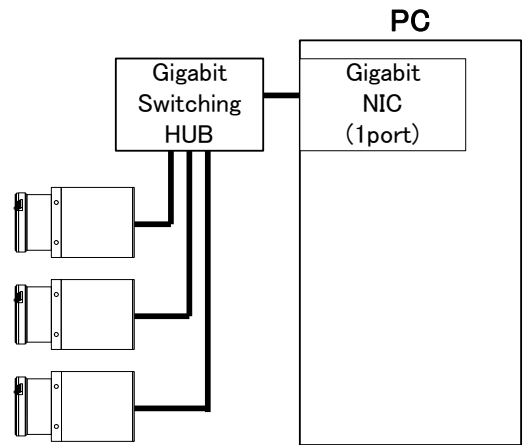

Figure 3-1-2 Example of connection for 1 PC

3.2 Input / Output Connectors and Indicator

The layout of input /output connectors and the indicator lamp are as follows.

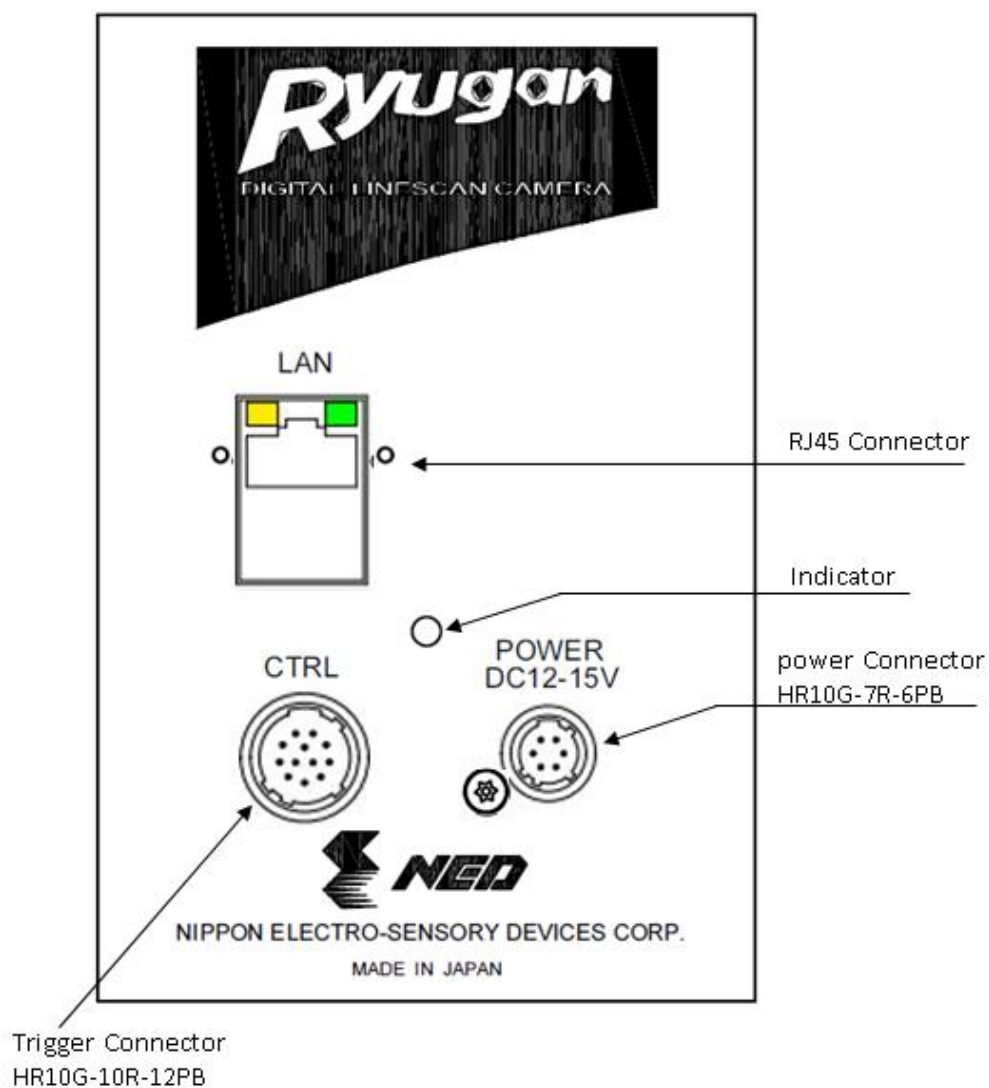

Figure 3-2-1 Input/Output Connectors and Indicator

3.3 Power Supply Connection

6 pin round shape push-pull lock type connector for Power supply.

The pin assignment of the power supply connector is shown below.

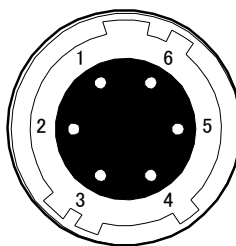

Figure 3-3-1 Power Supply Connector (HR10G-7R-6PB)

Table 3-3-1 Pin Assignment of Power Supply Connection

No	NAME	Color of Cable	No	NAME	Color of Cable
1	DC12~15V	White	4	GND	Green
2	DC12~15V	Red	5	GND	Black
3	DC12~15V	NC	6	GND	NC

The camera requires a single power supply (DC+12 to +15V).

- ◆ When selecting a power source, choose one with the capacity to allow for in-rush current. (15W or more recommended)
 - ◆ Insert the cable plug securely until it locks into position. This is to prevent the connector from coming loose during power transmission.
 - ◆ Do not remove the cable while image data is being transmitted
- Compatible Cable (Compatible plug): DGPS -10 (HIROSE : HR10A -7P - 6S)
 - Power supply voltage: DC+12 -15V (+/-5%)
 - Consumption Current (rated): DC+12V : 580mA
- ◆ If the lamp fails to illuminate even after power is switched on, turn off power immediately. Inspect wiring. Check the voltage and capacity of the supplied power source.
 - ◆ Provide a lightning surge protector on the power supply line for the camera used in the region where the possibility of thunder becomes high.
 - ◆ Do not share the power supply and ground connection with the apparatus such as the inverter controlled motor units or other devices that generate noise interference to avoid the failure and malfunction of the camera. Place the camera far away from the apparatus generating noise. Do not arrange the signal cables and the power supply cable for camera adjacently.

3.4 External Trigger Connector (HR10G-10R-12PB)

- ◆ Round shape push-pull lock type.
- ◆ The pin assignment of the External Trigger connector is shown below.

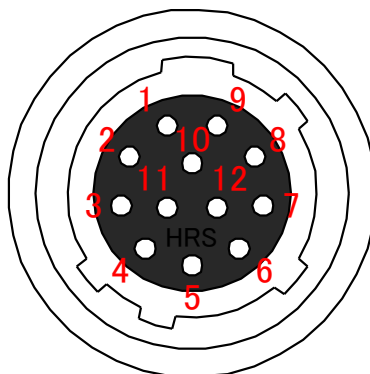

Figure 3-4-1 External Trigger Connector (HR10G-10R-12PB)

This is used in External Trigger mode, or External Frame Trigger mode.

Table 3-4-1 External Trigger Connector Pin Assignments

No	NAME	I/O	No	NAME	I/O
1	LineIn1-	IN	7	LineOut1+	OUT
2	LineIn1+	IN	8	LineIn2-	IN
3	LineIn3-	IN	9	LineIn2+	IN
4	LineIn3+	IN	10	Unused	NC
5	GND	GND	11	LineOut2-	OUT
6	LineOut1-	OUT	12	LineOut2+	OUT

Notes:

- 1) In order to ensure correct function of the external trigger, make sure to connect Pin 5 (Ground).
- 2) It is recommended to connect the external trigger cable's shield to GND on the power side.
- 3) Use a twisted pair cable, such that + and – are paired.
 - RS-422, LVDS and TTL are supported for input/output.
 - Polarity reversal & chatter prevention functions can be used on the input.

3.4.1 RS-422 Input

When using RS-422 for input, connect a differential input via twisted pair as shown in figure 3-4-2.

For correct operation, make sure to connect GND.

With RS-422, multiple receivers can be connected to one driver.

In such a case, only terminate the furthest receiver.

On this camera, setting the Terminate setting to ON activates the terminator.

Notes:

Do not terminate multiple receivers. The signal level will decrease and the signal will not be received correctly.

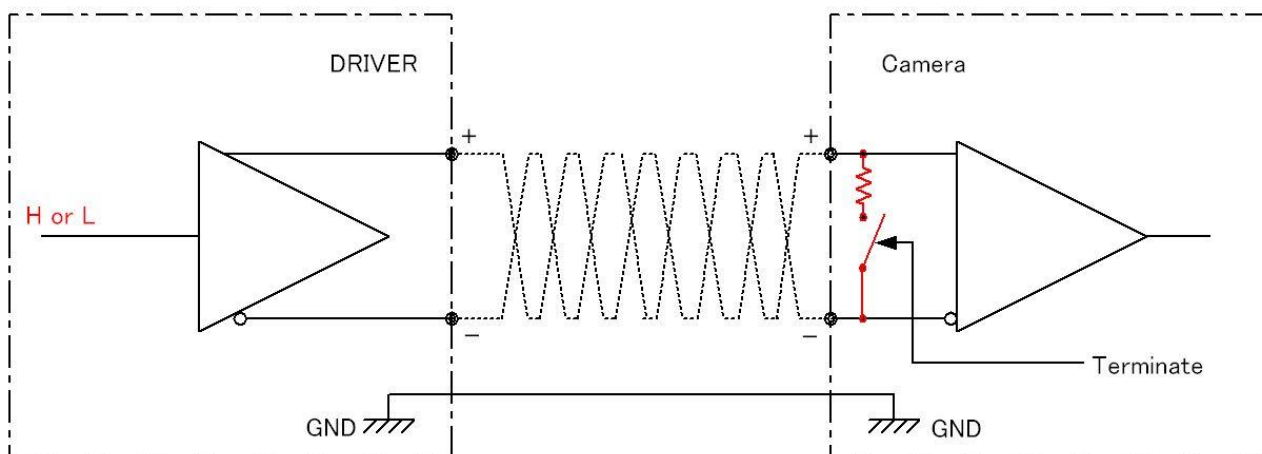

Figure 3-4-2 External Trigger Input Connection Diagram (differential)

3.4.2 LVDS Input

When using LVDS for input, connect in the same way as for RS-422, as Figure 3-4-2. Again, be sure to set Terminate to ON and activate the terminator. If the terminator is not activated the signal may not be received correctly.

Notes:

The LVDS Multidrop function is not supported. Only connect 1 device per driver.

If you need to send the signal to multiple cameras, it is possible to use the camera's external trigger output for a cascade connection.

3.4.3 TTL Input

To use TTL input, connect the camera as in figure 3-4-3 below.

To avoid damaging the device, do not input a signal to the – pin.

In addition, make sure that the Terminate setting is OFF and the terminator is inactive. If the terminator is active, the signal may not be received correctly.

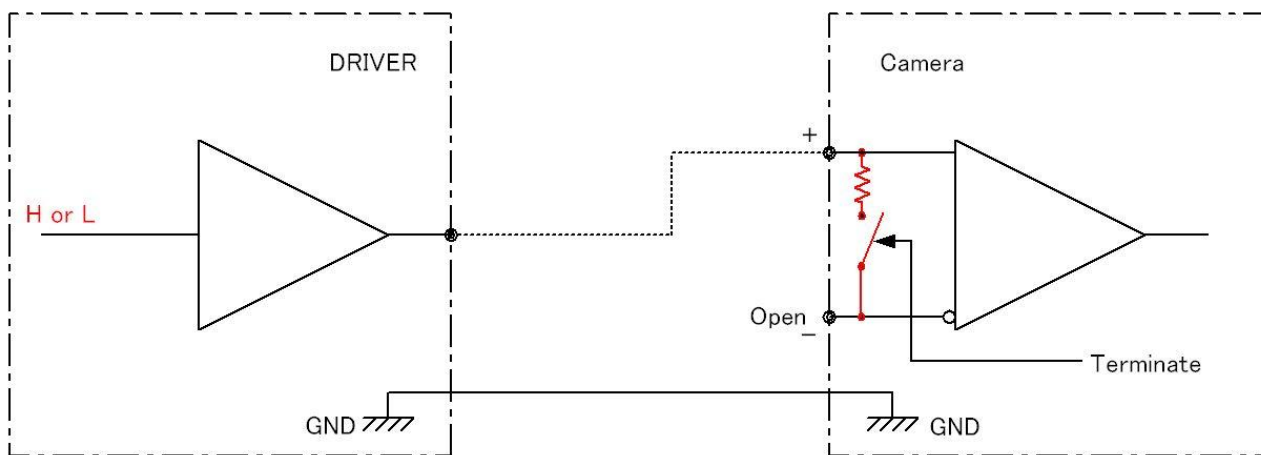

Figure 3-4-3 External Trigger Input Connection Diagram (TTL)

3.4.4 RS-422 Output

To use the RS-422 output, connect the camera with a differential twisted pair as shown in figure 3-4-4. For correct operation, make sure to connect GND.

Multiple receivers can be connected to 1 camera when using RS-422.

In such a case, only terminate the furthest receiver.

Notes:

Do not terminate multiple receivers. The signal level will decrease and the signal will not be received correctly.

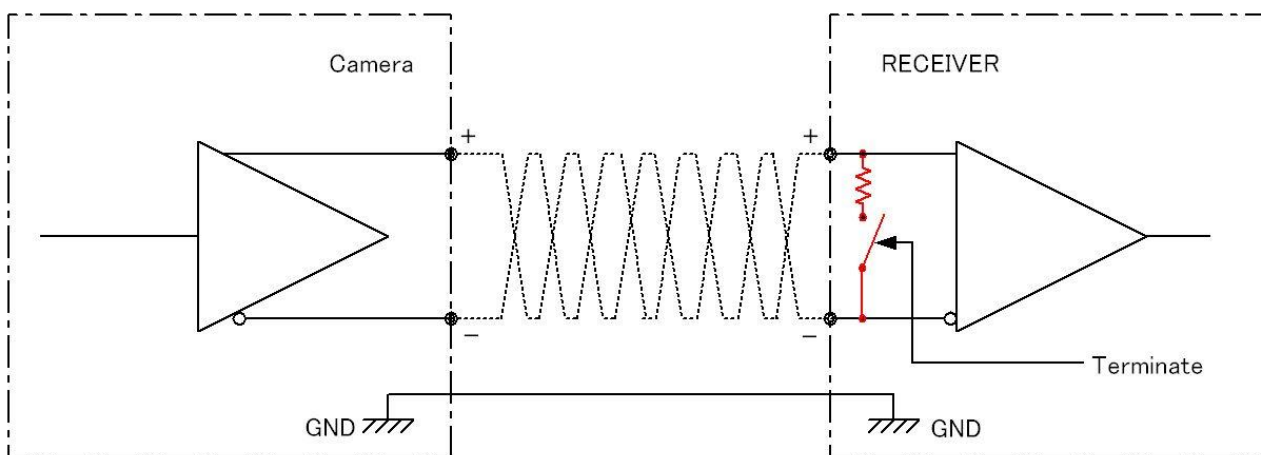

Figure 3-4-4 External Trigger Output Connection Diagram (RS-422)

3.4.5 LVDS Output

If the receiver requires LVDS input, it can be connected by attaching resistors to the camera outputs

Multidrop is not supported. Connect only 1 receiver per camera.

In addition, be sure to check that the receiver side must be terminated.

If not, correct signals may not be received.

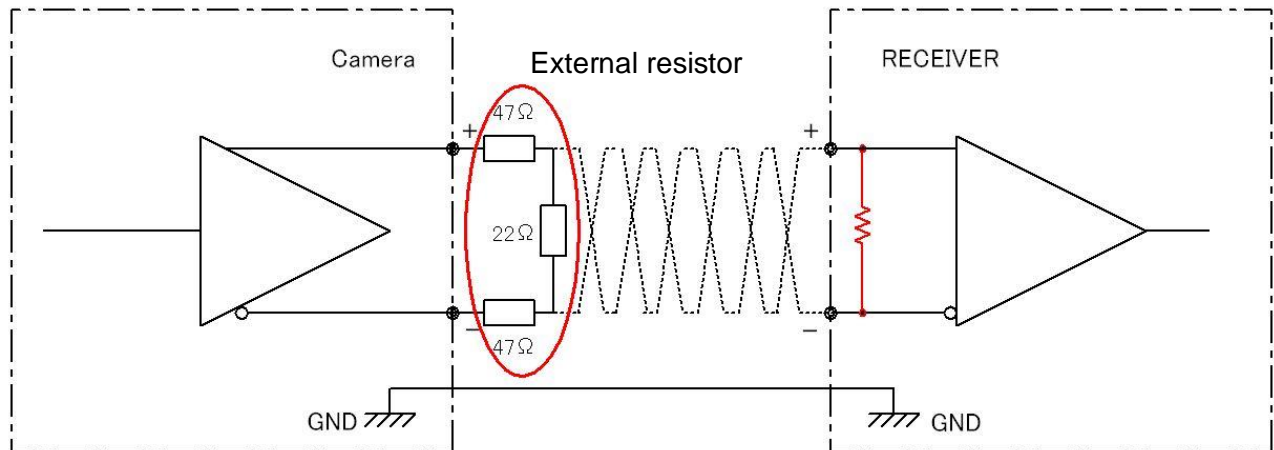

Figure 3-4-5 External Trigger Output Connection Diagram (LVDS)

3.4.6 TTL Output

To use TTL output, connect the camera output as shown in figure 3-4-6.

The Lo level output is 0V, the Hi level output is 3.3V.

To avoid damaging the device, do not connect the – pin.

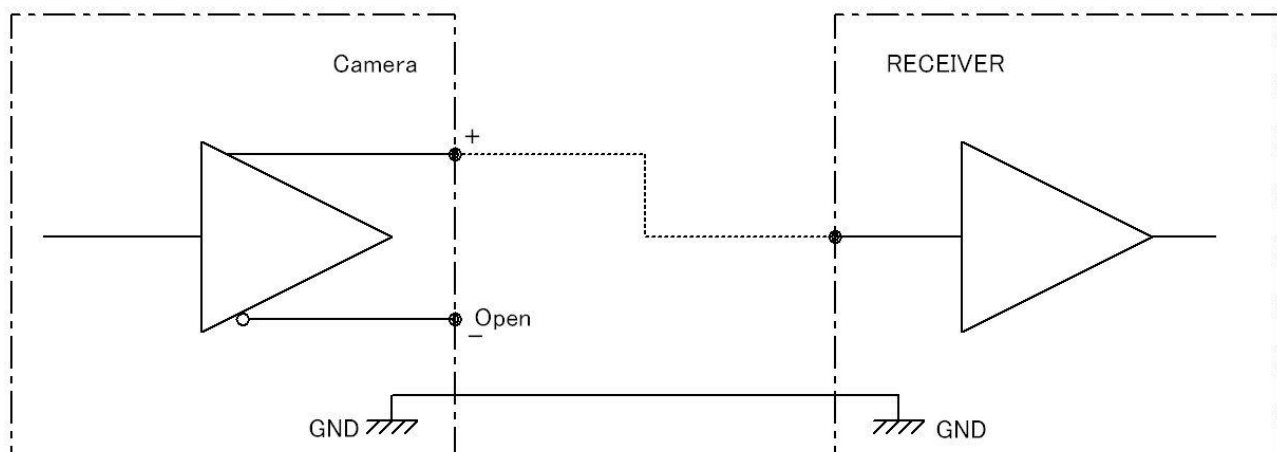

Figure 3-4-6 External Trigger Output Connection Diagram (TTL)

3.4.7 Relation of External Trigger Input and Output

The external trigger output uses the external trigger input driver as an intermediary as shown in figure 3-4-7. Therefore it is possible to switch the output ON/OFF by use of an enable resistor. For settings, see “4.2.6.4 Setting Line Source”.

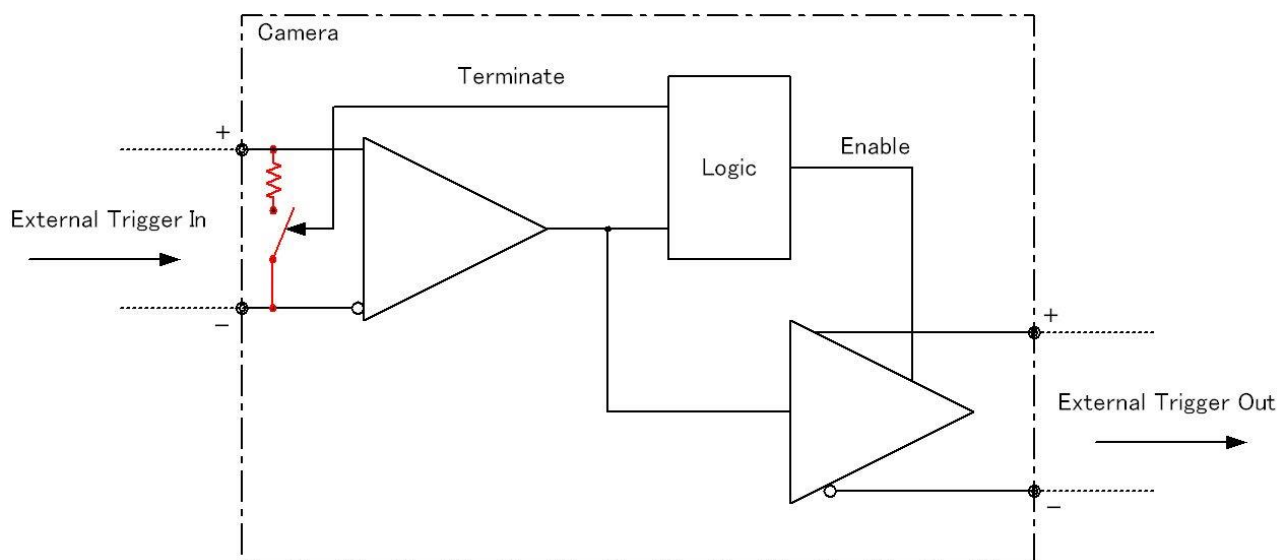

Figure 3-4-7 Relation of External Trigger Input and Output

3.5 RJ-45 Connector

The camera uses an RJ-45 connector complying with the Gigabit Ethernet standard (1000BASE-T). It can be connected to the LAN connector of your PC via a LAN cable (CAT-5e or above). For applications where there is a lot of vibration or movement, a screw-lock cable can be used.

Table 3-5-1 RJ-45 Connector pin assignments

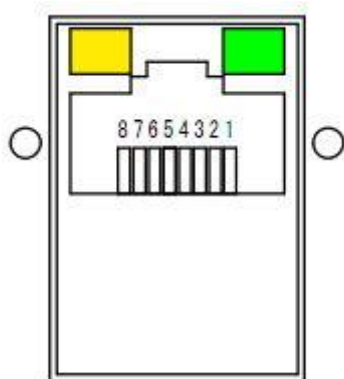

Figure 3-5-1 RJ-45 connector

No.	Name
1	TRP1+
2	TRP1-
3	TRP2+
4	TRP2-
5	TRP3+
6	TRP3-
7	TRP4+
8	TRP4-

3.6 LED indicating camera status

The LED is used to indicate power present and to the camera status.

Table 3-6-1 LED indication

Camera Status by LED Indicator	LAN is connected	LAN is not connected
Camera Power Supply is off	off (LED indication)	off (LED indication)
Camera Booting Up (Power On)	Lights orange	Lights orange
Disconnected cable	-	Lights red
Device Discovery	Blinks orange	-
Stand-by transmitting image packets	Lights green	-
Transmitting image packets	Blinks green	-

4 Camera Control

The camera supports the industrial camera control API GenI<|>Cam, and so camera settings can be easily changed from your application. The camera control registers are listed below. For instructions on how to change the settings, see the manual for your viewer software.

4.1 Flow of Camera Control

4.1.1 GenICam overview

- The camera control register information is saved inside the camera (XML file).
- The frame grabber board reads the XML file during Discovery, and acquires the register information.
- Camera control is enabled after Discovery.
Check your frame grabber's manual for how to perform device discovery.

4.1.2 List of Camera Control Registers

This camera supports GenICam SFNC 2.3 and the camera setting of the features shown in the table below can be controlled by software attached to the frame grabber board.

Table 4-1-1 List of Camera Control Registers

Control Item	RW	VAL <factory settings>	Description
<i>Device Control</i>			
DeviceUserID	RW	(ASCII code) <0x00>	User define ASCII code ASCII code is up to 15 characters The last of ASCII code is "NULL(0x00)"
DeviceTemperature Selector	RW	Mainboard	No need of Setting change
DeviceTemperature	R		DeviceTemperature (°C)
<i>Image Format Control</i>			
Width	RW	4~2048 <2048>	Number of pixels in a line. Must be a multiple of 4.
Height	RW	16~4096 <4096>	Number of lines in a frame.

OffsetX	RW	0~2044 <0>	X Offset Pixel No. Number of pixels in a line. Must be a multiple of 4.
ReverseX	RW	Forward (FALSE) Reverse (TRUE) <False>	Scan Direction
PixelFormat	RW	Mono8 / Mono10 / Mono10Packed <Mono8>	8bit Output 10bit Output 10bit Output (packed)
TestPattern	RW	Off/ GreyHorizontalRamp/ NED_GreyDiagonalRa mp <Off>	Test Pattern Output
Acquisition Control			
AcquisitionLineRate	RW	300~59523 <8176>	Hz(unit)
TriggerSelector	RW	FrameActive / ExposureStart / DummyFrameOutput	FrameActive : Enabling frame ExposureStart : Start (Each line) DummyFrameOutput
TriggerMode	RW	Off / On <Off>	Off : Disabling External trigger On : Enabling External trigger
TriggerSource	RW	NoConnect/ Encorder1/ LineIn1/ LineIn2/ LineIn3	NoConnect : No connection Encorder1 : Encoder selection LineIn1/LineIn2/LineIn3: External trigger
TriggerActivation	RW	Rising Edge/ Falling Edge/ Any Edge/ Level High/ Level Low	Rising Edge Falling Edge Any Edge : Rising & Falling Edge Level High : "H" level activation Level Low : "L" level activation
ExposureMode	RW	Timed / TriggerWidth <Timed>	Timed : Value of ExposureTime TriggerWidth: "H" time of External trigger
ExposureTime	RW	2.0~3331.0 <120.0>	0.1μsec / step

Analog Control			
NED_AnalogGain	RW	x100~x1000 <x100>	x1 / x2 / x3 / x4 / x5 / x6 / x8 / x10
GainSelector	RW	All	No need of Setting change
Gain	RW	1.000000~2.000000 <1.000000>	x1~x2 0.001957 / step
BlackLevelSelector	RW	All	No need of Setting change
BlackLevel	RW	-127~127 <0>	-63...63(0.5DN/step at 8bit) -254...254(2DN/step at 10bit)
Digital IO Control			
LineSelector	RW	LineIn1/ LineIn2/ LineIn3/ LineOut1/LineOut2	Input: LineIn1/ LineIn2/ LineIn3 Output: LineOut1/LineOut2
LineMode	R	Input/Output	No need of Setting change
LineInverter	RW	True / False <False>	True : Input Invert ON False : Input Invert Off
Line Format	RW	TTL /RS422NotTerminate /RS422Terminate /LVDS <TTL>	TTL : TTL Output RS422NotTerminate : RS422 (without terminal resistance) RS422Terminate : RS422 (with terminal resistance) LVDS : LVDS 出力
NED_LineMaskTimeR	RW	0~100000 <0>	0~100000μsec
NED_LineMaskTimeF	RW	0~100000 <0>	0~100000 μsec
Encoder Control			
EncoderSelector	R	Encoder1	No need of Setting change
EncoderSourceA	RW	Off/ LineIn1/LineIn2 /LineIn3	Encoder signal (A-phase)
EncoderMode	RW	Four Phase/ High Resolution	Four Phase : Combination of A & B phases One cycle of 4-state (with filtering) High Resolution: One cycle of 1-state

			(without filtering)
EncoderDivider	RW	1~200 <1>	One pulse by Pulse number input
EncoderOutputMode	RW	Off/Position Up/ Position Down/ Direction Up/ Direction Down/ Motion	Signal output setting mode for status of of moving object
EncoderTimeout	RW	0.000~60000000.000 <0.000>	Time out period 0~60000000 μsec
EncoderResetSource	RW	Off/ Acquisition Start/ Acquisition End/ Frame Start/ Frame End/ LineIn1/ LineIn2/ LineIn3	
EncoderResetActivation	RW	Rising Edge/ Falling Edge/ Any Edge/ Level High/ Level Low	Rising Edge Falling Edge Any Edge : Rising & Falling Edge Level High : "H" level activation Level Low : "L" level activation
EncoderReset	W	/	Software reset of encoder (Independent of EncoderResetSource)
EncoderValue	RW	0~999999 <0>	Reads and writes Encoder counting
User Set Control			
UserSetSelector	RW	Default/ UserSet1	Default : factory settings UserSet1 : user settings 1
UserSetLoad	W	/	Reads settings from internal memory when 1 is written
UserSetSave	W	/	Saves Current camera set values by UserSetSelector in the memory
NED additional features			

NED_FFMode	RW	Disable/ Factory white/ User white/ User black+Factory white/ User black+User white <Factory white>	Correction OFF/ Factory black correction+ Factory white correction/ Factory black correction+ User arbitrary white correction/ User arbitrary black correction+ Factory white correction/ User arbitrary black correction+ User arbitrary white correction
NED_PRNUTarget	RW	1~1023 <800>	Target value of correction level (10bit DN)
NED_PRNUCalibration	W		Acquiring the data of user arbitrary white correction and saving it in the memory
NED_FPNCalibration	W		Acquiring the data of user arbitrary black correction and saving it in the memory

4.2 Details on register system

4.2.1 Category

The following ten(10) categories are available as the camera control register. When you select the camera type number from the list of "Features name", these categories are shown.

<u>Categories</u>	<u>(Reference)</u>
1. Device Control	(for Device temperature)
2. Image Format Control	(for Imaging)
3. Acquisition Control	(for Exposure, Trigger)
4. Analog Control	(for Gain, Offset)
5. Digital IO Control	(for Line selector)
6. Encoder Control	(for Encoder)
7. User Set Control	(for Memory Loading and saving)
8. Transport Layer Control	(for GIG-E IF)
9. NED additional features	(for Pixel Correction)
10.NED factory only	(No use)

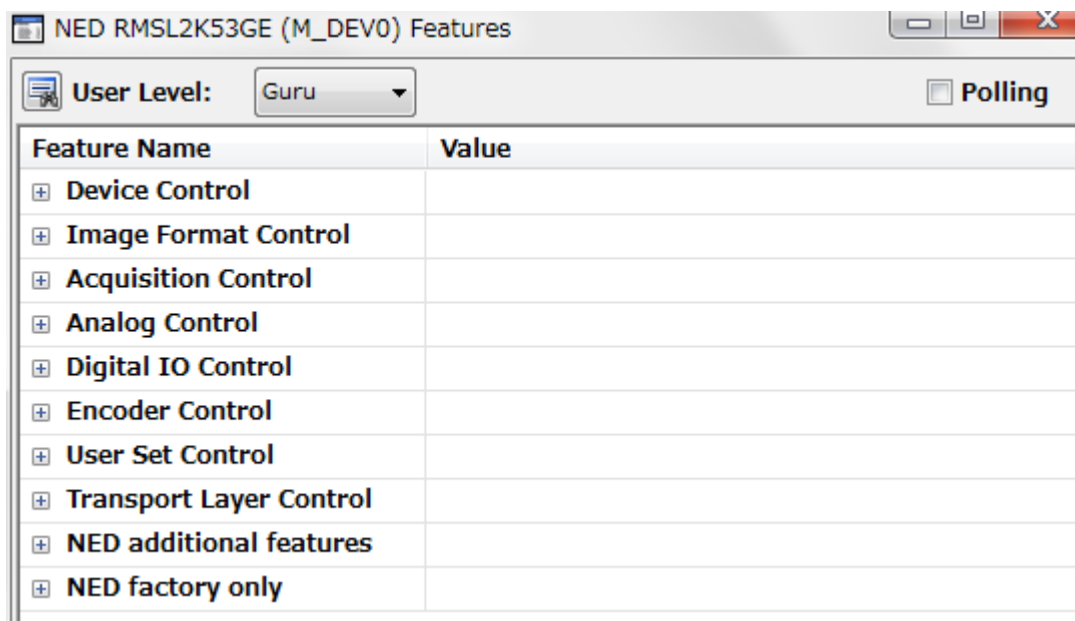

4.2.2 Device Control

4.2.2.1 Displaying Temperature of Camera

Displays the temperature of camera inside.

- Register name Device Temperature
- Displaying Value (°C)

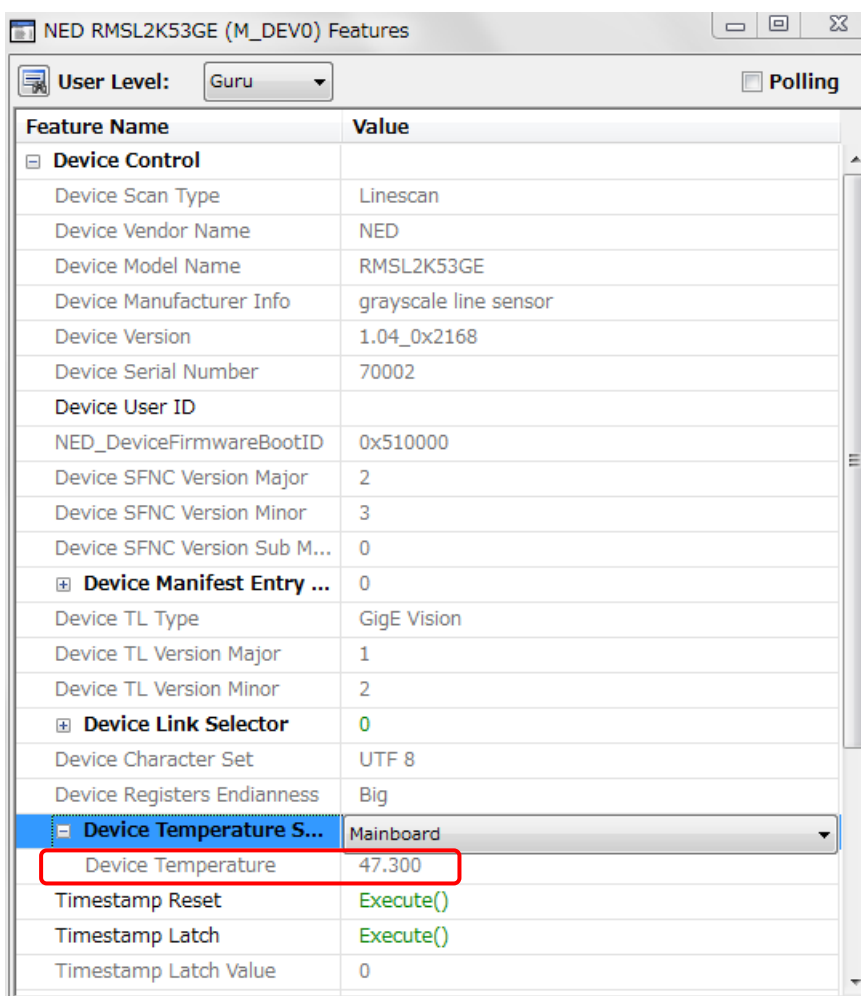

The screenshot shows a software window titled "NED RMSL2K53GE (M_DEV0) Features". At the top, there is a "User Level:" dropdown menu set to "Guru" and a "Polling" checkbox. Below this is a table with two columns: "Feature Name" and "Value". The table is expanded to show the "Device Temperature S..." section, which is highlighted in blue. The "Device Temperature" row is circled in red, showing a value of 47.300. Other rows include "Device Scan Type" (Linescan), "Device Vendor Name" (NED), "Device Model Name" (RMSL2K53GE), "Device Manufacturer Info" (grayscale line sensor), "Device Version" (1.04_0x2168), "Device Serial Number" (70002), "Device User ID", "NED_DeviceFirmwareBootID" (0x510000), "Device SFNC Version Major" (2), "Device SFNC Version Minor" (3), "Device SFNC Version Sub M..." (0), "Device Manifest Entry ..." (0), "Device TL Type" (GigE Vision), "Device TL Version Major" (1), "Device TL Version Minor" (2), "Device Link Selector" (0), "Device Character Set" (UTF 8), "Device Registers Endianness" (Big), "Timestamp Reset" (Execute()), "Timestamp Latch" (Execute()), and "Timestamp Latch Value" (0).

Feature Name	Value
Device Control	
Device Scan Type	Linescan
Device Vendor Name	NED
Device Model Name	RMSL2K53GE
Device Manufacturer Info	grayscale line sensor
Device Version	1.04_0x2168
Device Serial Number	70002
Device User ID	
NED_DeviceFirmwareBootID	0x510000
Device SFNC Version Major	2
Device SFNC Version Minor	3
Device SFNC Version Sub M...	0
Device Manifest Entry ...	0
Device TL Type	GigE Vision
Device TL Version Major	1
Device TL Version Minor	2
Device Link Selector	0
Device Character Set	UTF 8
Device Registers Endianness	Big
Device Temperature S...	Mainboard
Device Temperature	47.300
Timestamp Reset	Execute()
Timestamp Latch	Execute()
Timestamp Latch Value	0

4.2.3 Image Format Control

4.2.3.1 OffsetX and Width Settings

By using the 2 settings OffsetX and Width, a specific region only can be read out from the camera. The range of values is as follows:

- OffsetX: 0~2044
- Width: 4~2048

Notes:

OffsetX and Width can both only be set in multiples of 1.

e.g. OffsetX = 5 is not possible.

In addition, if the total of OffsetX and Width exceeds 2048, the input will not be accepted.

First, reduce one value, then increase the other.

(e.g. 1) To go from OffsetX = 0, Width = 2048 to OffsetX = 512, Width = 1024.

First, set Width to 1024, then set OffsetX to 512.

(e.g. 2) To go from OffsetX = 512, Width = 1024 to OffsetX = 0, Width = 2048.

First, set OffsetX to 0, then set Width to 2048.

As shown below, setting OffsetX = a, Width = b results in the region a + 1~a + b being specified.

(e.g.) To specify pixel 513~ pixel 1536, set OffsetX = 512、Width = 1024.

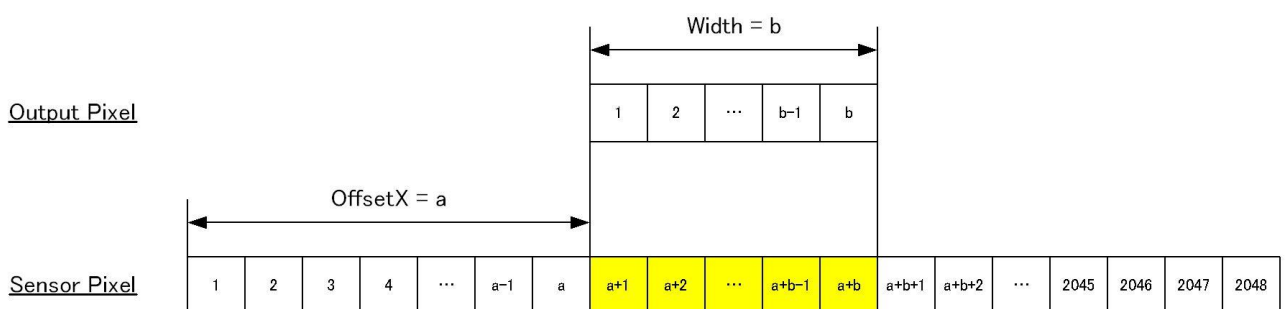

Figure 4-2-3-1 Valid Pixel Region

4.2.3.2 Height Setting

The Height parameter is used to set the number of lines in 1 frame.

The range of values is as follows:

- Height : 16~2048

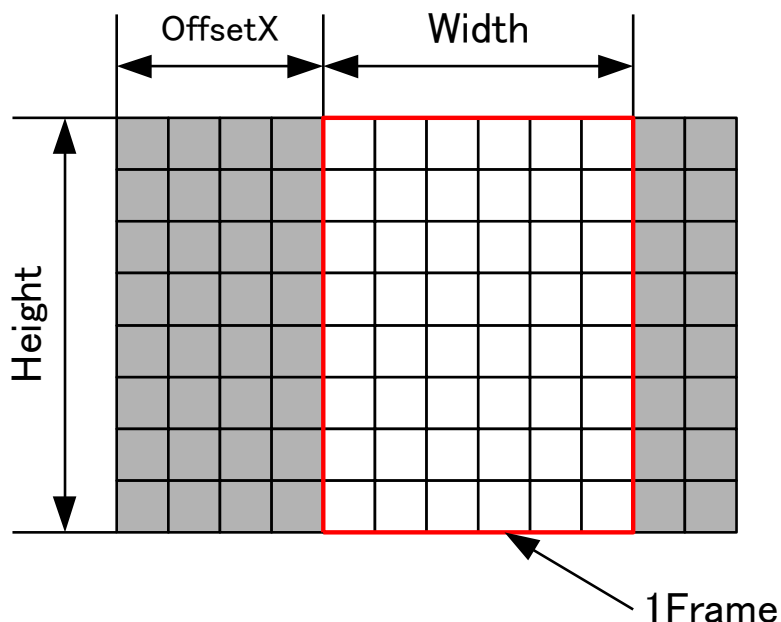

Figure 4-2-3-2 Area of 1 Frame

Notes:

The time for 1 frame can be calculated as follows:

$$1 \text{ Frame period (us)} = 1 \text{ Line Scan Period (us)} \times \text{Height}$$

Depending on the scan period and the height setting, it is possible that your application may time out.

In such a case, either change the above settings or the timeout period in your application.

4.2.3.3 Scan Direction

Switches scanning direction.

- Register name Reverse X
- VAL Forward (FALSE)
Reverse (TRUE)

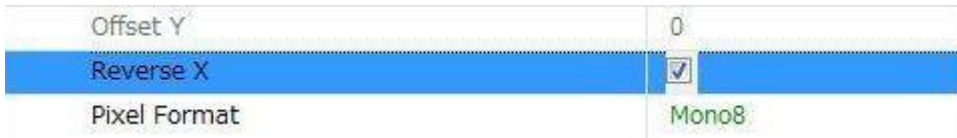

4.2.3.4 Pixel Format Setting

The Pixel Format parameter is used to select the video output format.

Supported formats are as follows:

- Register name Pixel Format
- VAL Mono8 / Mono10 / Mono10Packed

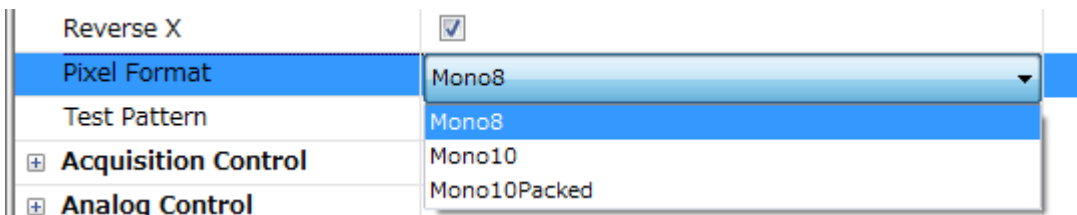

The pixel layout of each format is as below:

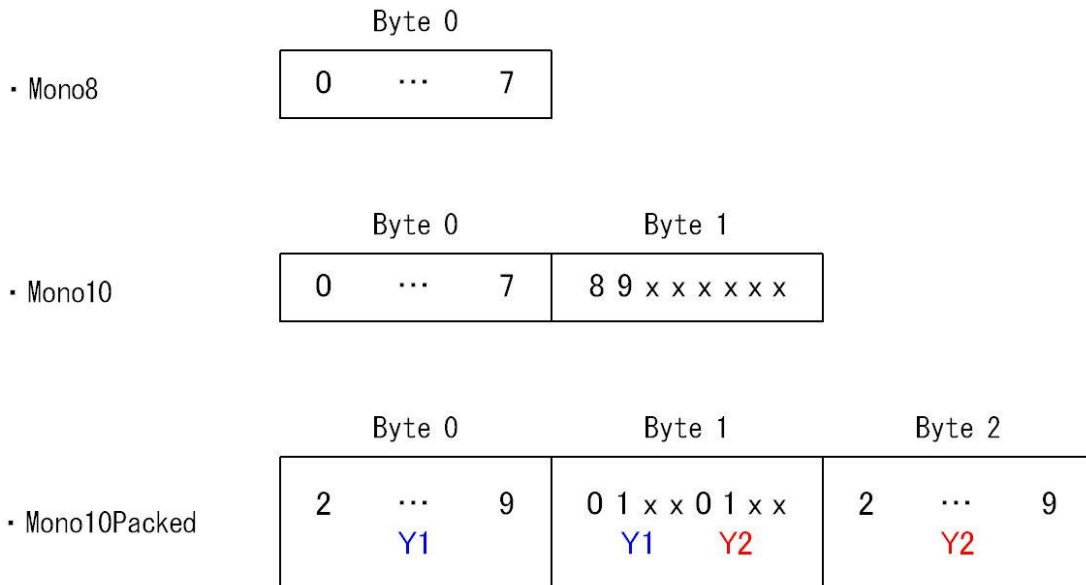

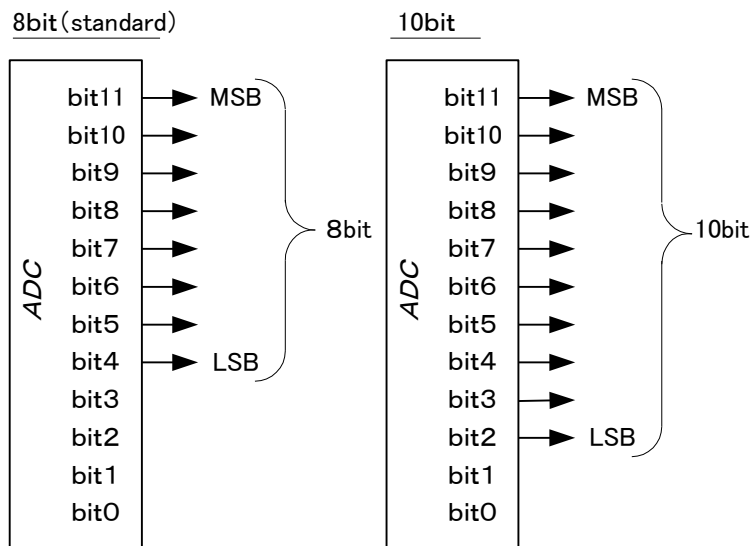

Figure 4-2-3-4-1 Pin Assignments of Digital Data

- ◆ The A/D converter of the camera has a 10-bit resolution. For 8-bit output, the upper 8-bit signal can be output as video data.

4.2.3.5 Test Pattern

The test pattern function allows you to check that data is being transferred correctly from the camera.

- Register name Test Pattern
- VAL Off / GreyHorizontalRamp / NED_Grey Diagonal Ramp

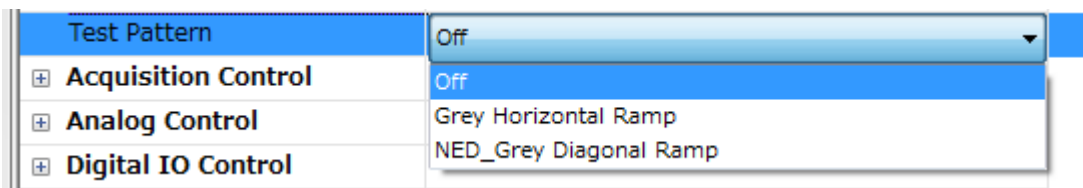

When GreyHorizontalRamp is selected, the below pattern is output.

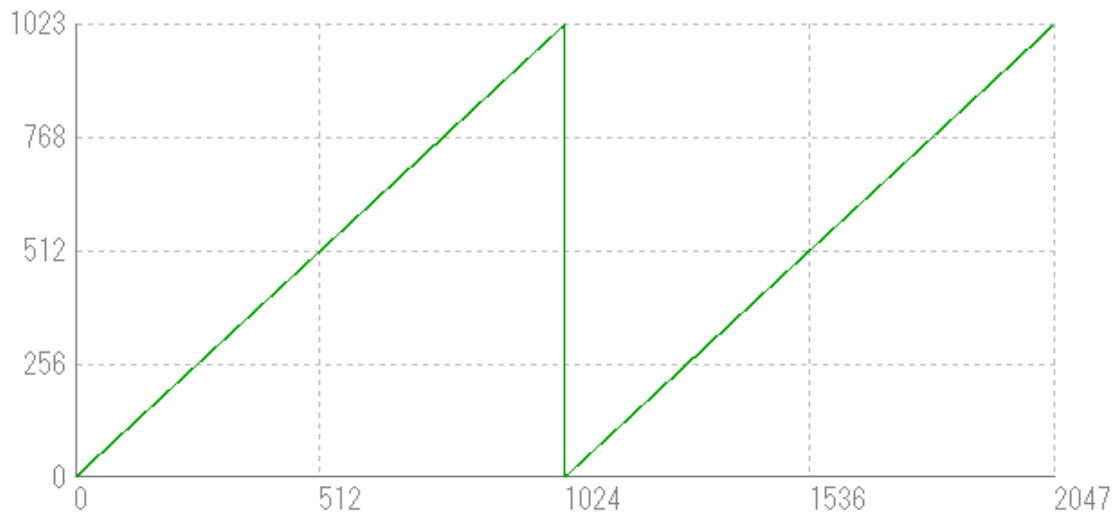

Figure 4-2-3-5-1 Test Pattern of 10bit 2048 Pixels(GreyHorizontalRamp)

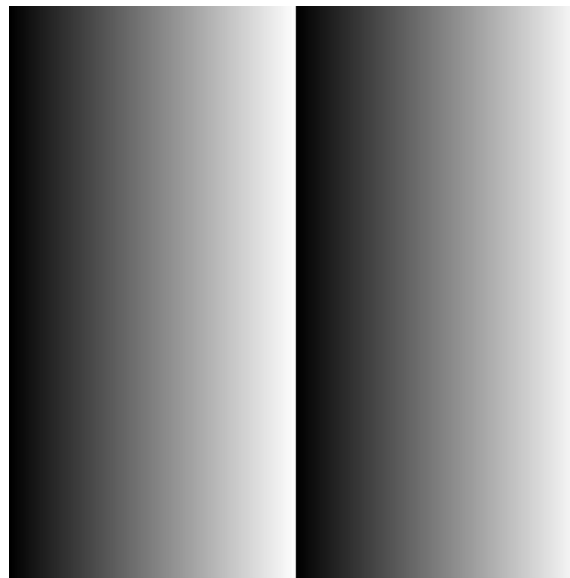

Figure 4-2-3-5-2 Test Image of 10bit 2048 Pixels(GreyHorizontalRamp)

It increases in increments of 1DN to 1023DN in order from the first pixel 0DN. This pattern is repeatedly output.

When NED_GreyDiagonalRamp is selected, the below pattern is output.

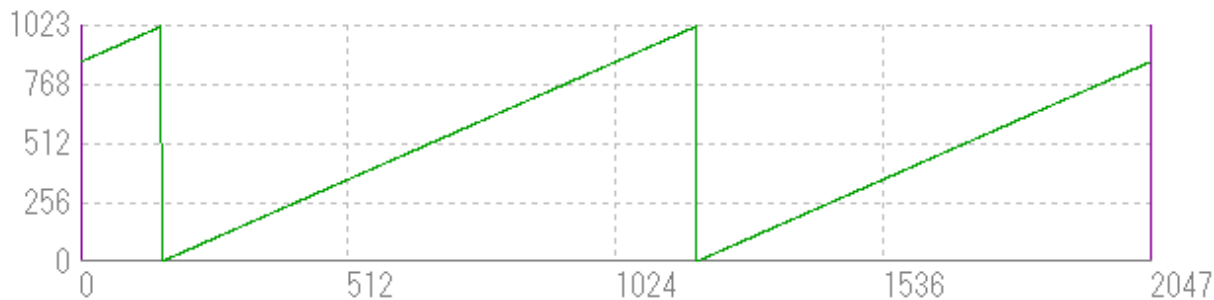

Figure 4-2-3-5-3 Test Pattern of 10bit 2048 Pixels(NED_GreyDiagonalRamp)

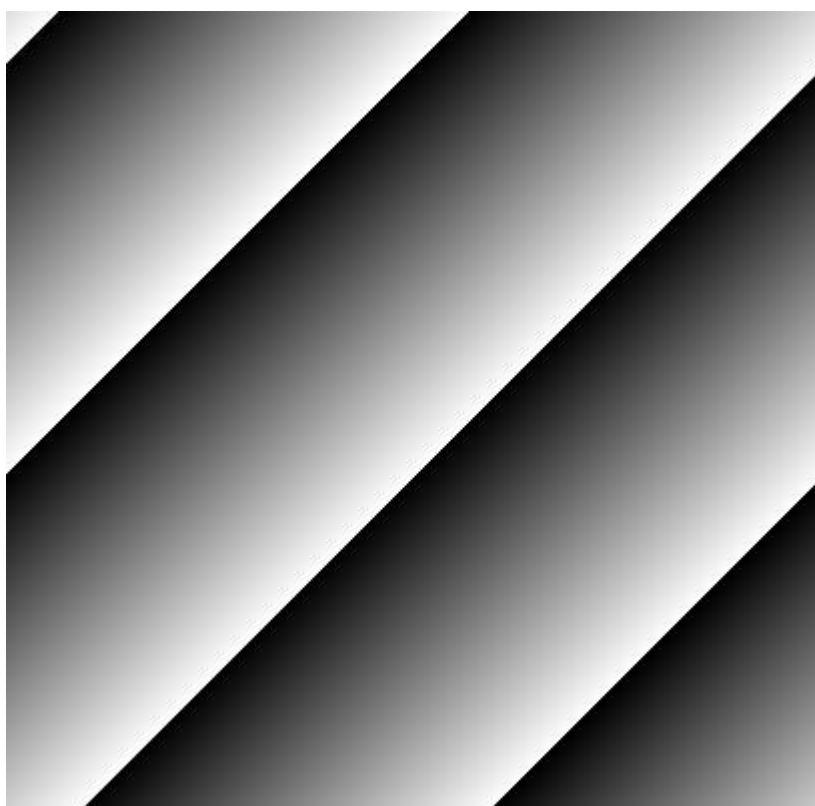

Figure 4-2-3-5-4 Test Image of 10bit 2048 Pixels(NED_GreyDiagonalRamp)

The value increases by 1DN each pixel, up to 1023DN from 0DN in both X-direction (horizontal direction) and Y-direction (vertical direction) in 10-bit mode, the pattern repeats.

The value increases by 1DN each pixel, up to 255DN from 0DN in both X-direction (horizontal direction) and Y-direction (vertical direction) in 8-bit mode, the pattern repeats.

4.2.4 Acquisition Control

4.2.4.1 Setting Line Rate

Sets the Line Rate.

- Register name Acquisition Line Rate

- VAL 300~59523(*1) (Hz)

(Example) (When 8176Hz is set as the line rate)

Acquisition Line Rate : 8176

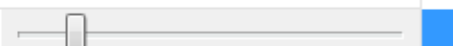
[-] Acquisition Control	
Acquisition Mode	Continuous
Acquisition Start	Execute()
Acquisition Stop	Execute()
Acquisition Line Rate	8176.000 
Acquisition Line Rate Enable	<input checked="" type="checkbox"/>
[+] Trigger Selector	Exposure Start
NED_DummyFrameOutput...	0.000
Exposure Mode	Timed
Exposure Time	14.500

- * 1) The maximum acquisition line rate
= 59kHz(when outputting 1024 pixels or less)
53kHz(when more than the above)

It may become lower than the maximum acquisition line rate depending on the processing time of PC.

- * 2) The reciprocal of the line rate (1/Acquisition Line Rate) is set in increments of 0.100μs.
When a value of (1/Acquisition Line Rate) is not divisible in 100ns, the real set value is different as follows.

(Example)

- When Acquisition Line Rate is set to 15000Hz, the real set value becomes 15015Hz.
- When Acquisition Line Rate is set to 30000Hz, the real set value becomes 30030H.

The value of Exposure Time may be changed automatically when the value of Acquisition Line Rate is too large.

The values are roughly set according to the following formula.

$$\text{Exposure Time} \leq (1 / \text{Acquisition Line Rate}) - 2.3 \mu\text{s}$$

4.2.4.2 Setting Trigger Selector

Sets the Trigger.

- Register name Trigger Selector
- VAL Frame Active, Exposure Start or DummyFrameOutput

(Example)

Trigger Selector : Exposure Start

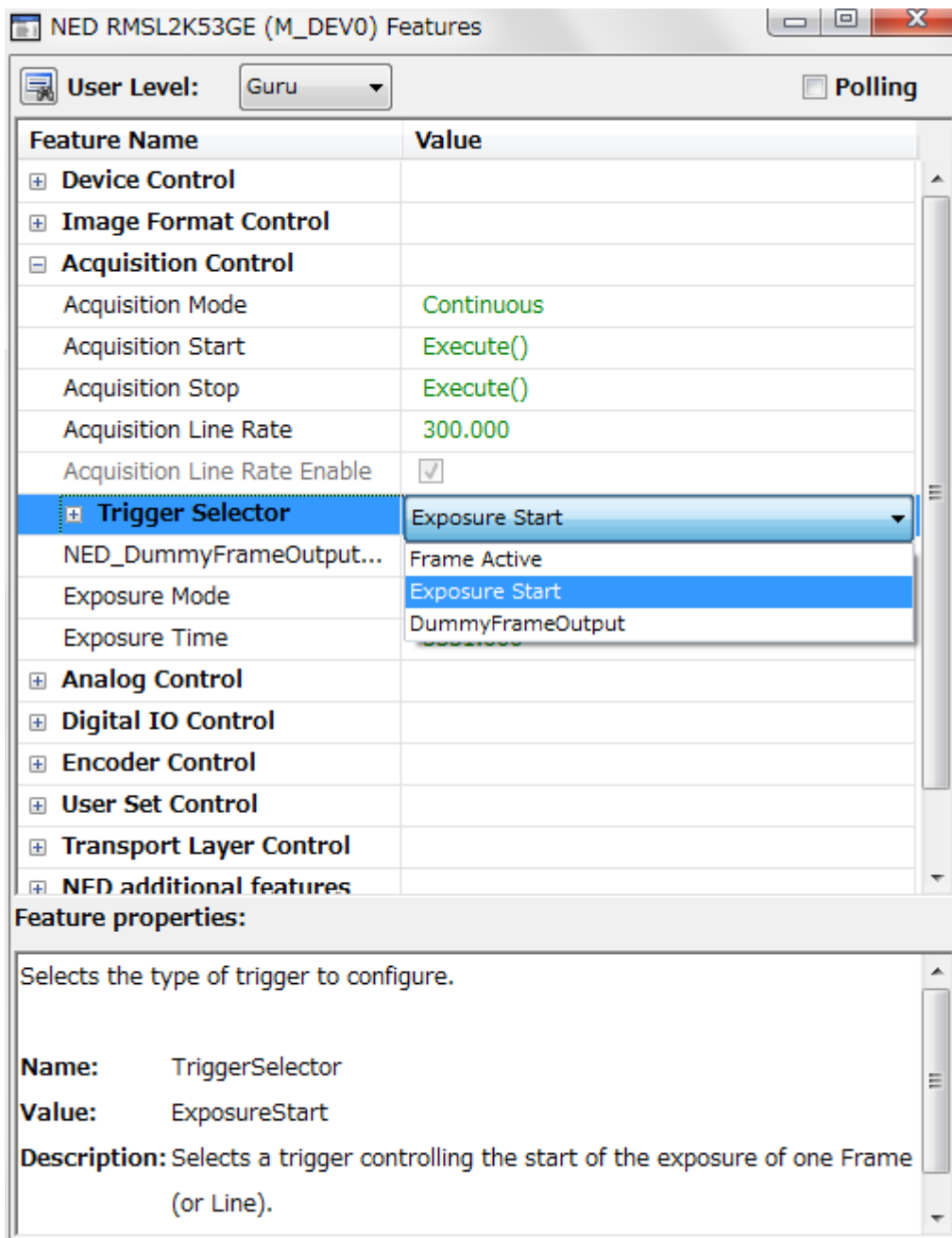

4.2.4.3 Setting Permission for using External Trigger

Sets the “Trigger Mode” of Register name to get permission for using the External trigger. Select “On” on the “Trigger Mode” if the External trigger is used.

- Register name Trigger Mode
- VAL Off / On (Disable/Enable)

(Example)

Trigger Mode: On

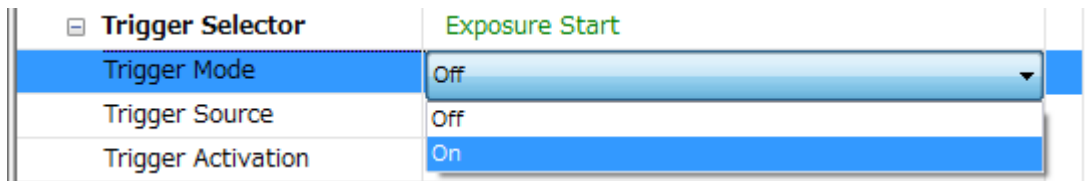

* Make sure that the trigger packet is supplied from the frame grabber board to the camera before the “Trigger Mode” is changed from “Off(Disable) to “On(Enable)” to get permission for using the External trigger.

See 4.3 Examples of External trigger setting.

4.2.4.4 Setting Exposure Mode

Sets the “Exposure Mode” of Register name when the “Trigger Mode” is set to “On” (Enable).

- Register name Exposure Mode
- VAL Timed (The set value of the “Exposure Time” is used as the exposure time)
Trigger Width (The “H” time of “Trigger pulse” of the “External Start” is used as the exposure time)

(Example)

Exposure Mode : Timed



4.2.4.5 Setting Exposure Time

Sets the value of the exposure time.

The setting is enable;

when “Off” on the “Trigger Mode” is set, or

when “On” on the “Triger Mode” and “Timed” on the “Exposure Mode” are set.

- Register name Exposure Time

- VAL 2.000~3331.000 (0.1100μs step)

(Example)

Exposure Time : 1000.000

Exposure Mode	Timed
Exposure Time	1000.000
⊕ Analog Control	

* The value of the Acquisition Line Rate” may be changed automatically when the value of the “Exposure Time” is too large.

The values are roughly set according to the following formula.

$$\text{Acquisition Line Rate} \leq 1 / (\text{Exposure Time} + 2.3) \mu\text{s}$$

4.2.5 Analog Control

4.2.5.1 Setting Analog gain

The camera can adjust the analog gain (x1 to x10 in 8 steps).

- Register name NED_AnalogGain

- VAL X 1.00 ~ X 10.00

⊖ Analog Control	
NED_AnalogGain	x 1.00(0.0dB)
⊕ Gain Selector	x 1.00(0.0dB)
⊕ Black Level Selector	x 2.00(5.0dB)
Gamma	x 3.00(9.5dB)
	x 4.00(12.0dB)
⊕ Digital IO Control	x 5.00(14.0dB)
⊕ Encoder Control	x 6.00(15.6dB)
⊕ User Set Control	x 8.00(18.1dB)
	x10.00(20.0dB)

4.2.5.2 Setting Digital gain

The camera can adjust the digital gain(x1 to x2 in 512 steps).

- Register name Gain
- VAL 1.000~2.000 (0.001957step)



4.2.5.3 Setting Offset

The offset can be adjusted. It is possible to set it in the adjustable range of $-254\sim254$ (DN) when 10bit is output $-63\sim63$ (DN) when 8bit is output.

- Register name Black Level
- VAL $-127\sim127$ (1step)

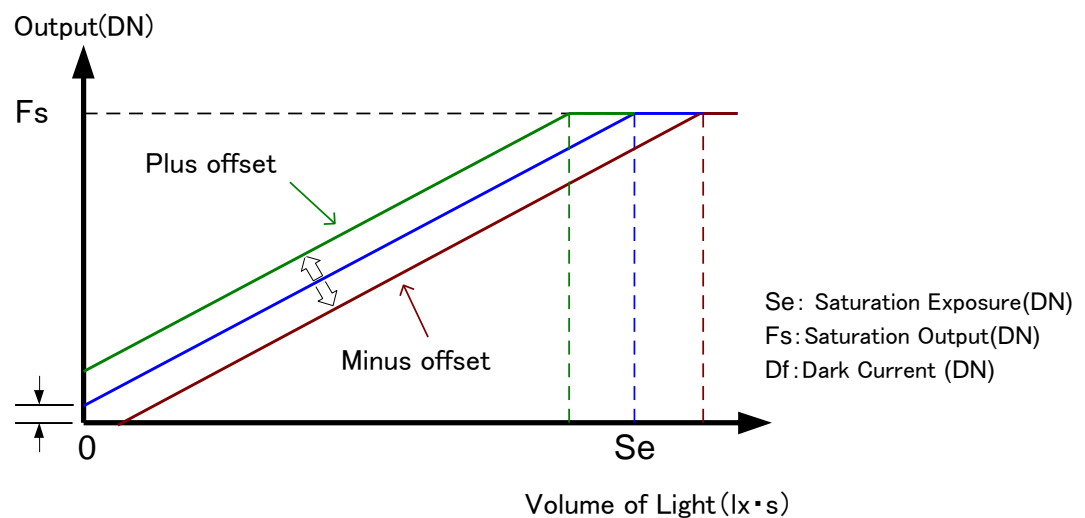

Figure 4-2-5-3-1 Offset Adjustment

Note:

- 1) Adjust amount of offset in accordance with the requirements of your camera system.
- 2) The gradients of lines do not change.

4.2.6 Digital IO Control

4.2.6.1 Setting I/O signal

Sets I/O signal.

- Register name Line Selector
- VAL LineIn1/LineIn2/LineIn3 (input)
 LineOut1/LineOut2 (output)

[-] Digital IO Control	
[-] Line Selector	LineIn1
Line Mode	LineIn1
Line Inverter	LineIn2
Line Status	LineIn3
Line Source	LineOut1
Line Format	LineOut2
NED_LineMaskTimeR	TTL
NED_LineMaskTimeF	0
NED_LineMaskTimeF	0
[+] Encoder Control	

* See Table 3-4-1 External Trigger Connector Pin Assignments for the relation with VAL (LineIn/ LineOut) and the corresponding pins.

4.2.6.2 Setting Line Mode

The “Line Mode” can be set automatically when the “Line Selector” is set.

When “LineIn” of “Line Selector” is set, “Input” appears.

When “LineOut” of “Line Selector” is set, “Output” appears.

[-] Digital IO Control	
[-] Line Selector	LineOut2
Line Mode	Output

4.2.6.3 Setting Input Signal Polarity Reversal

Sets Input signal polarity reversal.

- Register name Line Inverter
- VAL False(Uncheck the box) (Disabling Input signal polarity reversal)
 True(Check the box) (Enabling Input signal polarity reversal)

(Example) (Enabling Input signal polarity reversal)

Line Inverter : On

4.2.6.4 Setting Line Source

Sets Line Source.

- Register name Line Source
- VAL Off/Acquisition Active/Frame Active/Exposure Active/Encoder1/
LineIn1/LineIn2/LineIn3 (input)
LineOut1/LineOut2 (output)

[-] Digital IO Control	
[-] Line Selector	LineOut2
Line Mode	Output
Line Inverter	<input type="checkbox"/>
Line Status	<input checked="" type="checkbox"/>
Line Source	Off
Line Format	Off
NED_LineMaskTimeR	Acquisition Active
NED_LineMaskTimeF	Frame Active
[+] Encoder Control	Exposure Active
[+] User Set Control	Encoder 1
[+] Transport Layer Control	LineIn1
	LineIn2
	LineIn3

4.2.6.5 Setting I/O Signal Format

Sets I/O signal format.

- Register name Line Format
- VAL TTL
RS422NotTerminate
RS422Terminate
LVDS

[-] Digital IO Control	
[-] Line Selector	LineIn1
Line Mode	Input
Line Inverter	<input type="checkbox"/>
Line Status	<input type="checkbox"/>
Line Source	
Line Format	TTL
NED_LineMaskTimeR	TTL
NED_LineMaskTimeF	RS 422 Not Terminate
[+] Encoder Control	RS 422 Terminate
[+] User Set Control	LVDS

* See Section 3.4.1 to 3.4.7 for Input and Output of RS422, LVDS and TTL.

4.2.6.6 Setting External Line Trigger Chattering Prevention

This register enables the feature to prevent chattering or other unexpected variations in the signal.

- Register name : NED_LineMaskTimeR
- : NED_LineMaskTimeF
- VAL : 0~1000000 (change invalid period) : μs)

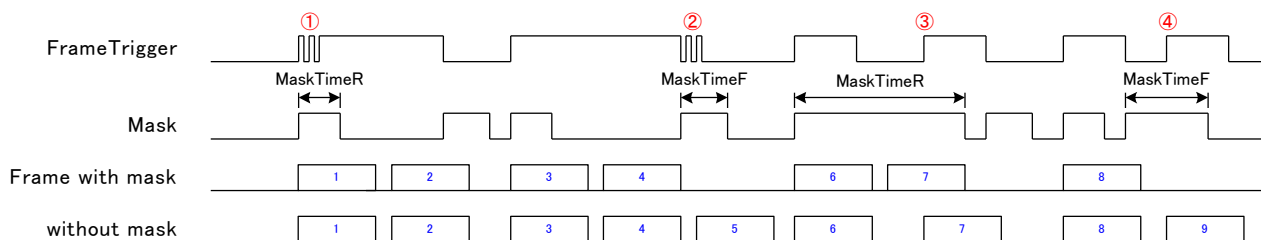

Figure 4-2-6 External Line Trigger Input Mask Effect

- ①NED_LineMaskTimeR: The time during which changes in the signal rising edge are invalid
- ②NED_LineMaskTimeF: The time during which changes in the signal falling edge are invalid
Using this function you can control the generation of unwanted frames due to unexpected variations in the signal.
- ③If you set NED_LineMaskTimeR to too large a value, valid trigger changes may go undetected and frames will not be generated, so set the value as small as possible.
- ④If you set NED_LineMaskTimeF to too large a value, valid trigger changes may go undetected and unwanted frames will be generated, so set the value as small as possible.

4.2.7 Encoder Control

4.2.7.1 Setting Encoder Control

Sets Encoder control.

Only “Encoder1” can be selected.

- Register name Encoder Selector
- VAL Encoder1

⊕ Digital IO Control	
Encoder Control	
Encoder Selector	Encoder 1
Encoder Source A	Off
Encoder Source B	Off
Encoder Mode	Four Phase
Encoder Divider	1
Encoder Output Mode	Off
Encoder Status	Encoder Static
Encoder Timeout	0.000
Encoder Reset Source	Off
Encoder Reset Activation	Rising Edge
Encoder Reset	Execute()
Encoder Value	0
Encoder Value At Reset	0
⊕ User Set Control	

4.2.7.2 Setting Input Signal for Encoder Source A

Sets Input signal for Encoder Source A.

- Register name Encoder Source A
- VAL off
 LineIn1
 LineIn2
 LineIn3

(Example) (when “LineIn1” is set on “Encoder Source A”)

Line Format : LineIn1

Encoder Control	
Encoder Selector	Encoder 1
Encoder Source A	Off
Encoder Source B	Off
Encoder Mode	LineIn1
Encoder Divider	LineIn2
Encoder Output Mode	LineIn3
Encoder Output Mode	Off
Encoder Status	Encoder Static
Encoder Timeout	0.000
Encoder Reset Source	Off
Encoder Reset Activation	Rising Edge
Encoder Reset	Execute()
Encoder Value	0
Encoder Value At Reset	0
User Set Control	

4.2.7.3 Setting Input Signal for Encoder Source B

Sets Input signal for Encoder Source B.

- Register name Encoder Source B
- VAL
 - Off
 - LineIn1
 - LineIn2
 - LineIn3

(Example) (when “LineIn2” is set on “Encoder Source B”)

Line Format : LineIn2

Encoder Control	
Encoder Selector	Encoder 1
Encoder Source A	LineIn1
Encoder Source B	Off
Encoder Mode	Off
Encoder Divider	LineIn1
Encoder Output Mode	LineIn2
Encoder Output Mode	LineIn3

4.2.7.4 Setting Encoder Mode

Selects the method to decode the encoder pulse. This can be used for trigger signals.

- Register name Encoder Mode
- VAL Four Phase (The combination by rising and falling edges on pulses of Phase A and Phase B makes four states. Four states are counted as one cycle of pulse of "Four-phase". This can filter the unnecessary signals such as the chattering signals by noise)
- High Resolution (Any changes by rising and falling edges on pulses of Phase A or Phase B are counted as one cycle of pulse of "High Resolution". This may not work as noise filter for the chattering signals)

(Example)

Encoder Mode: Four Phase (when "Four Phase" is set on "Encoder Mode")

Encoder Mode	Four Phase
Encoder Divider	Four Phase
Encoder Output Mode	High Resolution

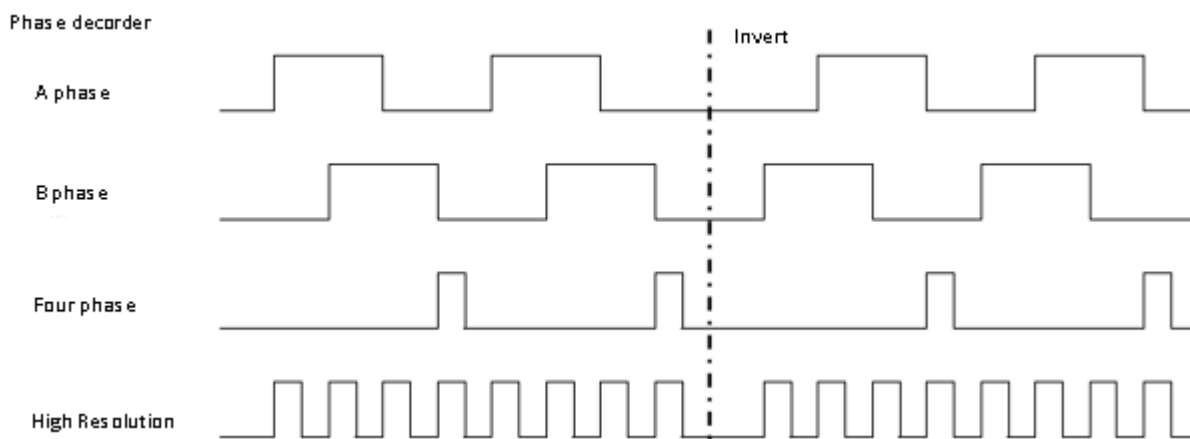

4.2.7.5 Setting Encoder Divider

Sets numbers of Encoder Divider for outputting the pulse when the encoder input of the specified number is acquired.

- Register name Encoder Divider
- VAL 1~200

(Example) (when "10" is set on "Encoder Divider")

Encoder Divider: 10

4.2.7.6 Setting Encoder Output Mode

Sets the Encoder Output Mode to output the pulse.

- Register name Encoder Output Mode
- VAL Off (Output no pulse)
 - Position Up (Pulse output when new position in normal rotation direction is detected)
 - Position Down (Pulse output the pulse when new position in reverse rotation direction is detected)
 - Direction Up (Pulse output in normal rotation direction)
 - Direction Down (Pulse output in reverse rotation direction)
 - Motion (Pulse output in normal and reverse rotation directions)

(Example) (when "Position Up" is set on "Encoder Output Mode")

Encoder Output Mode : Position Up

Encoder Output Mode	Off
Encoder Status	Off
Encoder Timeout	Position Up
Encoder Reset Source	Position Down
Encoder Reset Activation	Direction Up
Encoder Reset	Direction Down
	Motion

4.2.7.7 Setting Encoder Status

Reads the Encoder status.

- Register name Encoder Status
- VAL Encoder Up (Encoder counter increasing)
 - Encoder Down (Encoder counter decreasing)
 - Encoder Idle (Encoder counter stopping)
 - Static (No operation in time of Encoder Timeout)

4.2.7.8 Setting Time of Encoder Timeout

Sets the time of Encoder Timeout. The status becomes "Encoder Idle" if the Encoder counter does not change during this time.

- Register name Encoder Timeout
- VAL 0~60000000

(Example) (when "10μsec" is set on "Encoder Timeout")

Encoder Timeout : 10

4.2.7.9 Setting Encoder Reset Signal

Sets the Encoder Reset signal.

- Register name Encoder Reset Source
- VAL Off(No Reset Source)
Acquisition Start / Acquisition End
Frame Start / Frame End
LineIn1 / LineIn2 / LineIn3

(Example) (when “Frame End” is set on “Encoder Reset Source”)

Encoder Reset Source : Frame End

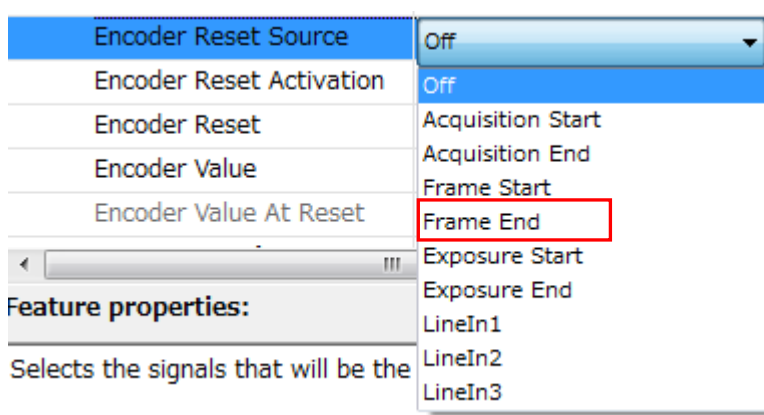

4.2.7.10 Setting Encoder Reset Activation

Sets the “Encoder Reset Source” to reset.

- Register name Encoder Activation
- VAL Rising Edge (Reset by rising edge of Input signal)
Falling Edge (Reset by falling edge of Input signal)
Any Edge (Reset by rising and falling edges of Input signal)
Level High (Reset state during the period of “High” of Input signal)
Level Low (Reset state during the period of “Low” of Input signal)

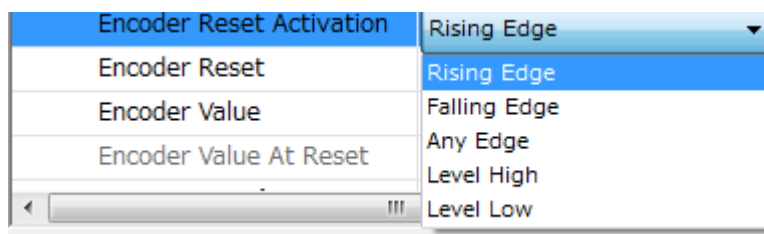

4.2.8 User Set Control

4.2.8.1 Setting Memory Selection

Selects the location of camera setting data saved in the flash memory.

- Register name User Set Selector
- VAL Default / User Set 1 (Factory setting/ User setting)

(Example)

User Set Selector: User Set 1

User Set Control	
User Set Selector	User Set 1
User Set Load	Default
User Set Save	User Set 1

4.2.8.2 Setting Memory Loading

(Reading the camera setting data from the flash memory)

The camera setting data selected by “User Set Selector” is read from the flash memory and is used to operate the camera.

- Register name User Set Load
- VAL Execute()

(Example)

User Set Selector : User Set 1 (Selecting User setting)

User Set Load : Execute() (Loading User setting data)

User Set Control	
User Set Selector	User Set 1
User Set Load	Execute()
User Set Save	Execute()

4.2.8.3 Setting Memory Saving

(Saving the camera setting data into the flash memory)

The current camera setting data is saved in the flash memory.

- Register name User Set Save
- VAL Execute()

(Example)

User Set Selector : User Set 1 (Selecting User setting)

User Set Save : Execute() (Saving User setting data)

User Set Control	
User Set Selector	User Set 1
User Set Load	Execute()
User Set Save	Execute()

4.2.8.4 Resetting Factory camera setting

Follow the steps below to set the camera setting at the time of factory shipping.

- ① Select “Default” on “User Set Selector”

User Set Selector: Default

User Set Control	
User Set Selector	User Set 1
User Set Load	Default
User Set Save	User Set 1

- ② Set the “Execute()” on “User Set Load “

User Set Load : Execute()

The camera setting data at the time of factory shipping is read from the flash memory and is used to operate the camera.

User Set Selector	
Default	
User Set Load	Execute()
User Set Save	Execute()

* The camera setting data at factory shipping can be used to operate the camera by the step ② until the power for camera is off.

After the power is off and then on, the previous camera setting data is used to operate the camera unless the step ③ below is not followed.

- ③ Set the “Execute()” on “User Set Save “

User Set Save : Execute()

The camera setting data at factory shipping can be used to operate the camera even after the power for camera is off.

User Set Load	Execute()
User Set Save	Execute()

4.2.9 Transport Layer Control

4.2.9.1 Setting Persistent IP

Sets IP by checking the box.

- Register name Gev Current IP Configuration Persistent IP
- VAL True/False

[-] Transport Layer Control	
Payload Size	4194304
[-] GigE Vision	
[+] Gev Supported Option Selector	User Defined Name
[-] Gev Interface Selector	0
Gev MAC Address	D8-16-0A-00-70-02
Gev Current IP Configuration LLA	<input checked="" type="checkbox"/>
Gev Current IP Configuration DHCP	<input checked="" type="checkbox"/>
Gev Current IP Configuration Persistent IP	<input type="checkbox"/>
Gev Current IP Address	169.254.100.100
Gev Current Subnet Mask	255.255.0.0
Gev Current Default Gateway	169.254.100.1
Gev Persistent IP Address	
Gev Persistent Subnet Mask	
Gev Persistent Default Gateway	

← 固定 IP にしたい
場合はチェックを
入れる



Gev Current IP Configuration Persistent IP	<input checked="" type="checkbox"/>
Gev Current IP Address	169.254.100.100
Gev Current Subnet Mask	255.255.0.0
Gev Current Default Gateway	169.254.100.1
Gev Persistent IP Address	169.254.100.100
Gev Persistent Subnet Mask	255.255.0.0
Gev Persistent Default Gateway	169.254.100.1

← 固定 IP アドレス
← サブネットマスク
← デフォルトゲートウェイ

When the box is checked, Persistent IP address, Persistent Subnet mask and Persistent Default gateway are effective.

4.2.9.2 Packet Size

Packet size can be changed via the GevSCPSPacketSize camera register.

- Register name : GevSCPSPacketSize
- VAL : 512 ~ 9152 *

Transport Layer Control	
Payload Size	4194304
GigE Vision	
GeV Supported Option Selector	User Defined Name
GeV Interface Selector	0
Gev First URL	Local:NED_RyuganGEV_20180201_01.xml;FF..
Gev Second URL	File:NED_RyuganGEV_20180201_01.xml
Gev Timestamp Tick Frequency	62500000
Gev CCP	Control Access
Gev MCP Host Port	0xC24F
Gev MCDA	169.254.1.1
Gev MCTT	0
Gev MCRC	0
Gev MCSP	0x0
GeV Stream Channel Selector	0
Gev SCP Interface Index	0
Gev SCP Host Port	0xC24E
Gev SCPS Fire Test Packet	<input type="checkbox"/>
Gev SCPS Do Not Fragment	<input checked="" type="checkbox"/>
Gev SCPS Packet Size	8964
Gev SCPD	0
Gev SCDA	169.254.1.1

1 packet contains not only image data, but also a data header with transmission information. Therefore, by increasing the packet size, the number of packets to send can be reduced, reducing the overall data volume.

Notes:

Do not set the size larger than your network's MTU (Maximum Transmission Unit). Doing so will result in image data not being able to be sent.

4.2.9.3 Packet Delay

Packet Delay can be set via the following register:

- Register name : Gev SCPD
- VAL : 0~4294967295

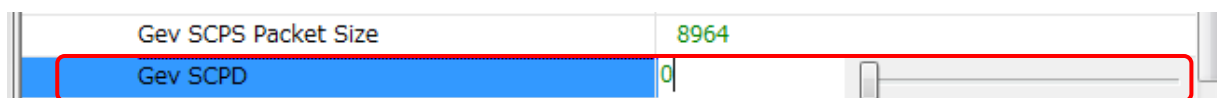

Notes:

Packet Delay is set to 0 at the time of shipping; however it should be set to as large a value as possible to obtain stable image data.

However, if the value is too large, the frame rate will drop. See 4.4 “Calculating the maximum value of packet delay” to set the most suitable value.

4.2.10 NED additional features

4.2.10.1 Setting Pixel Correction

Sets the method of the pixel correction.

- Register name NED_FFMode
- VAL Disable (Factory black correction)
- Factory white (Factory black and white correction)
- User white (Factory black and user white correction)
- User black + Factory white (User black and factory white correction)
- User black + User white (User black and user white correction)

(Example)

NED_FFMode: User white



4.2.10.2 Setting Pixel Correction Target Value

Sets the target level of the white pixel correction data.

Usually use “800” of factory setting as the target level but change it correspondingly.

- Register name NED_PRNUtarget
- VAL 0 to 1023 (in increments of 1DN)

(Example)

NED_PRNUtarget:800



4.2.10.3 Saving White Pixel Correction Data

Acquires current white pixel correction data and saves it in the flash memory. One set of correction data can be saved for each step of analog gain.

- Register name NED_PRNUCalibration
- VAL Execute()

(Example)

NED_PRNUCalibration: Execute()

NED_PRNUTarget	800
NED_PRNUCalibration	Execute()
NED_FPNCalibration	Execute()

4.2.10.4 Saving Black Pixel Correction Data

Acquires current black pixel correction data and saves it in the flash memory. One set of correction data can be saved for each step of analog gain.

- Register name NED_FPNCalibration
- VAL Execute()

(Example)

NED_FPNCalibration : Execute()

NED_PRNUCalibration	Execute()
NED_FPNCalibration	Execute()
NED_InternalResultString	OK

4.2.10.5 Setting conditions of White pixel correction and Black correction

◆ Setting conditions of white pixel correction

Remove the lens cap so that light enters the camera. Place a uniformly white object fully in the camera view. Now Arbitrary white correction data can be acquired.

When this is done with the lens attached, lens and illumination shading will also be corrected at the same time. However, dark and light details of the white object will be picked out, so the lens should be defocused.

◆ Setting condition of black pixel correction

Put on a lens cap to darken the camera view.

4.3 Setting Procedure of External Trigger Settings (for Examples)

4.3.1 One-phase Trigger setting (for Example)

This is the setting procedure in the case that “LineIn3” as “Line Selector” and “TTL” as “Line Format” are used.

- ① Setting No-Permission before using External Trigger
After selecting “Trigger Selector” in the categories of “Acquisition Control”, set as follows.
Trigger Selector : Exposure Start (See section 4.2.4.2)
Trigger Mode: Off (See section 4.2.4.3 but set “Off” at this time)

Note: Do not skip the step ① above, otherwise the wave pattern and the image may not be output properly.

- ② Setting “Line Selector” and “Format” of External Trigger Signal (LineIn1/ LineIn2/ LineIn3)
(TTL/RS422NotTerminate/RS422Terminate/LVDS)
After selecting “Line Selector” in the categories of “Digital IO Control”, (Example) “LineIn3” and “TTL”
Line Selector : LineIn3 (See section 4.2.6.1)
Line Format : TTL (See section 4.2.6.5)

Remark: Other External Trigger Signal format can be set on the remaining selection of “Line Selector”. These settings can be saved in selection of “Line Selector” respectively.

- ③ Selecting External Trigger Signal Type
External Trigger Signal Type can be set below.
After selecting “Trigger Sourcer” in the categories of “Acquisition Control”, set as follows.
(Example) “LineIn3” and “Rising Edge”
Trigger Source : LineIn3
Trigger Activation : Rising Edge
- ④ Setting Permission before using External Trigger Setting
After selecting “Trigger Mode” in the categories of “Trigger Selector”,

set as follows.

Trigger Mode : On (See section 4.2.4.3)

Remark: The above settings can be saved. (See section 4.2.8.3 “Setting Memory Saving”)

4.3.2 Two-phase Trigger setting (for Example)

This is the setting procedure in the case that “LineIn1” and “LineIn2” as “Line Selector” and “HighResolution” as “Encoder Mode” are used.

① Setting No-Permission before using External Trigger

After selecting “Trigger Selector” in the categories of “Acquisition Control”, set as follows.

Trigger Selector : Exposure Start (See section 4.2.4.2)

Trigger Mode : Off (See section 4.2.4.3 but set “Off” at this time)

Note: Do not skip the step ① above, otherwise the wave pattern and the image may not be output properly.

② Setting External Trigger Signal Format

(LineIn1/ LineIn2/ LineIn3) and
(TTL/RS422NotTerminate/RS422Terminate/LVDS)

Set this according to sections 4.2.6.1 and 4.2.6.5.

This setting is not required if the existing setting remains.

③ Selecting External Trigger Signal Type for Encoder Source A (LineIn1)

After selecting “Encoder Source A” in the category of “Encoder Control”, set as follows.

(Example) LineIn1

Encoder Source A: LineIn1

See section 4.2.7.2

④ Selecting External Trigger Signal Type for Encoder Source B

After selecting “Encoder Source B” in the category of “Encoder Control”, set as follows.

(Example) LineIn2

Encoder Source B: LineIn2

See section 4.2.7.3

⑤ Selecting Encoder Mode

After selecting “Encoder Mode” in the category of “Encoder Control” set as follows.

(Example) HighResolution

Encoder Mode: HighResolution

See section 4.2.7.4

⑥ Selecting External Trigger Signal Type

“External Trigger Signal Type” can be set below.

After selecting “Trigger Selector” in the category of “Acquisition Control”, set as follows.

(Example) Encoder 1 and Rising Edge

Trigger Source : Encoder1

Trigger Activation : Rising Edge

⑦ Setting Permission before using External Trigger Setting

After selecting “Trigger Mode” in the categories of “Trigger Selector”, set as follows.

Trigger Mode : On (See section 4.2.4.3)

Remark: The above settings can be saved. (See section 4.2.8.3 “Setting Memory Saving”)

4.4 Calculating the Maximum Value of Packet Delay

The maximum value for the packet delay setting can be calculated as below. In order to achieve the desired frame rate without dropping frames, it is necessary to set a value smaller than the maximum packet delay.

Payload Size = Width x Height x (No. of Bytes/pixel)

Mono8 : 1 Byte/pixel

Mono10 : 2 Bytes/pixel

Mono10Packed : 1.5Bytes/pixel

No. of packets in 1 frame = Payload Size / (Packet Size-Data Header:36 Bytes)

Transfer time for 1 frame=(Payload Size+No. of packets/frame x Data Header)
/Gigabit Ethernet Transfer Rate (Max 125 Mbyte/s)

Notes:

The maximum Gigabit Ethernet transfer rate may vary depending on the processing power of your PC and NIC. Allowing some margin, it is recommended to calculate around 110~120 Mbytes/s.

1 Frame Scan Period = 1 Line Scan Period x Height

1 Frame Time Margin = 1 Frame Scan Period - 1 Frame Transfer Period

Packet Delay Time = 1 Frame Time Margin / No. of packets/frame

Max. Packet delay value = Packet Delay time [ns] x 60 / 1000

e.g. Minimum scan period at 4096 pixels (Width: 4096, Height: 2048, Mono8,
1 Line Scan Period: 37.3us. Packet Size: 4000, Transfer Rate: 120Mbyte/s)

Payload Size = 8388608 (Bytes/Pixel)

No. of packets/frame = 2117

Transfer Period for 1 frame = 70540 [us]

1 Frame Scan Period = 76390 [us]

1 Frame Time Margin = 5850 [us]

Packet Delay Time = 2391 [ns]

Packet Delay Setting Value= **143**

(Framerate = 13fps)

4.5 Exposure Mode and Timing

The camera has three exposure modes.

4.5.1 Free run Exposure Mode

The free run exposure mode can be used when the “Trigger Mode” is “Off” (Disable). (See section 4.2.4.3 but set “Off” at this time)

The Acquisition Line Rate and the Programmable Exposure Time are set in the camera control registers.

The range of the settable Line rate and the programmable exposure time are shown below.

Table 4-5-1-1 Free Run Exposure Time

1/scan	Acquisition Line Rate (Hz)	300~59523
p	Exposure Time (μs)	2.000~3331.000 *

* The programmable exposure time (μs) can be set in increments of 0.100μs.

The relations of the programmable exposure time (μs) and the line rate (Hz) are as follows.

$$\text{Programmable exposure time} \leq (1 / \text{Line rate}) - 2.3 \mu\text{s}$$

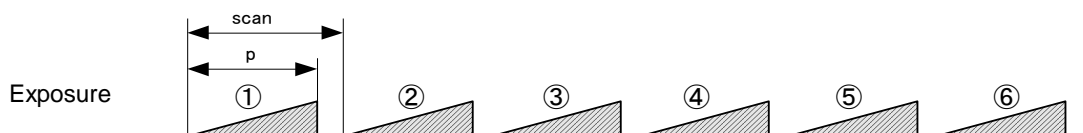

Figure 4-5-1 Free Run Exposure Mode

4.5.2 External Trigger (Timed) Exposure Mode

The external trigger (Timed) exposure mode can be used when "On" (Enable) on "Trigger Mode" and "Timed" on "Exposure Mode" are set.

The line period is determined by the time from rising edge to rising edge of the trigger pulse cycle. The start of each exposure is determined by the rising edge of the trigger pulse cycle. The exposure time is set by the programmable exposure time.

The range of the settable line period and the programmable exposure time are shown below

Table 4-5-2 External Trigger (Timed) Exposure Time

a	Trigger pulse H time (μs)	≥2.9
b	Trigger pulse L time (μs)	≥2.9
c	Trigger pulse cycle (μs)	≥18.8
p	Programmable exposure time (μs)	2.000~3331.000 *

* The programmable exposure time (μs) can be set in increments of 0.100μs.

The relations of the programmable exposure time (μs) and the line period (μs) are as follows.

$$\text{Programmable exposure time} \leq \text{Line period} - 2.3 \mu\text{s}$$

c: Line period (μs)

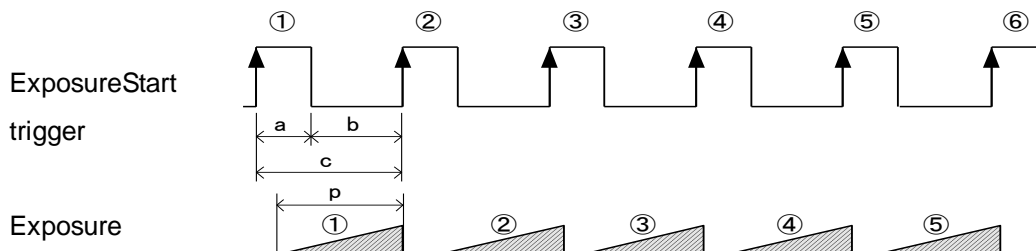

Figure 4-5-2 External Trigger (Timed) Exposure Mode

4.5.3 External Trigger (TriggerWidth) Exposure Mode

The external trigger (Trigger Width) exposure mode can be used when "On" (Enable) on "Trigger Mode" and "Trigger Width" on "Exposure Mode" are set.

The line period is determined by the time from rising edge to rising edge of the trigger pulse cycle. The start of each exposure is determined by the rising edge of the trigger pulse cycle. The exposure time is set by the trigger pulse H time.

The range of the settable line period is shown below.

Table 4-5-3 External Trigger (Trigger Width) Exposure Time

a	Trigger pulse H time (μs)	≥ 15.9
b	Trigger pulse L time (μs)	≥ 2.9
c	Trigger pulse cycle (μs)	≥ 18.8

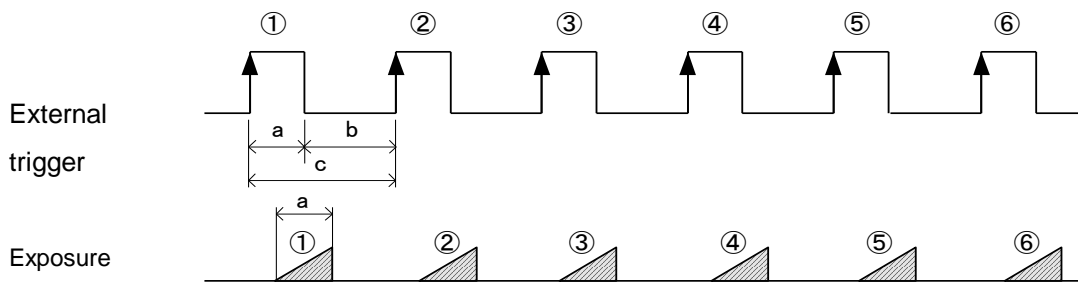

Figure 4-5-3 External Trigger (Trigger Width) Exposure Mode

4.6 Setting Offset

In the diagram below, the horizontal axis indicates the volume of light and vertical axis indicates the output.

F_s shows the output at saturation. D_d shows the output at darkness. (Both F_s and D_d are digital.) S_e shows for the saturation current, or the amount of exposure when the output saturates.

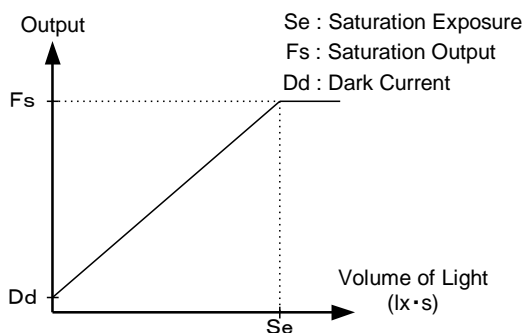

Figure 4-6-1 Saturation Exposure and Dark Current Output

By setting the offset, you can set the Y-intercept arbitrarily. D_F shows the digital offset value. The gradients of lines do not change.

See section 4.2.5.3 for setting Offset.

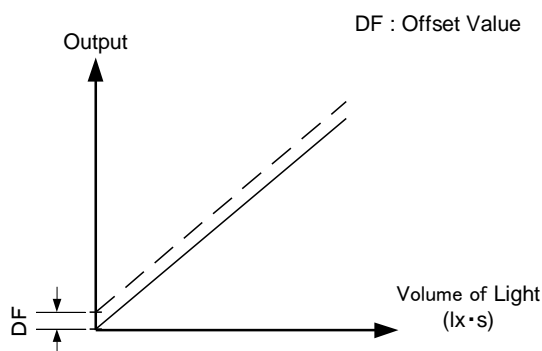

Figure 4-6-2 Offset Adjustment

- ◆ Adjust gain and offset to meet your system’s requirements.

4.7 Setting Gain

The camera can adjust the analog gain (x1 to X10.0 in 8 steps) and the digital gain. As the diagram below indicates, increasing the gain setting increases the slope of the camera's response curve and results in a higher camera output for a given amount of light.

See section 4.2.5.1 for setting Analog gain and section 4.2.5.2 for setting Digital gain.

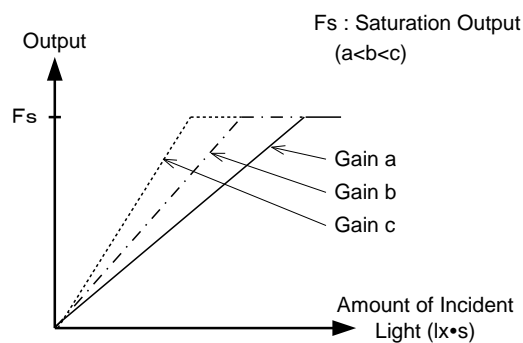

Figure 4-7-1 PGA Gain Adjustment

- ◆ Gain and noise values are proportionally related.
 - ◆ Adjust amount of gain in accordance with the requirements of your camera system.

Gain-Sensitivity is shown below.

Table 4-7-1 Gain-Sensitivity

	Analog Amplifier		Sensitivity (V/lx□s)
0	x1.00	0.0dB	100
1	x2.00	6.0dB	200
2	x3.00	9.5dB	300
3	x4.00	12.0dB	400
4	x5.00	14.0dB	500
5	x6.00	15.6dB	600
6	x8.00	18.1dB	800
7	x10.00	20.0dB	1000

Digital gain x1, Pixel correction: default, (Factory white correction data, Correction level 800DN)

4.8 Pixel Correction

Generally speaking, image sensors (CCD, CMOS and so on) have fixed pattern noise and photo response non-uniformity. When you use the lens, lens shadings and light sources also can cause non-uniformity. The camera is set to the optimal correction before shipping in order to provide images of high grade. The camera also has the function of user white correction to cope with lens shading and non-uniform illumination.

Cal_bl : Output data of each pixel at perfectly dark (factory correction)

Cal_wh : Output data of each pixel in uniform illumination (factory correction)
or in taking a picture of subject for correction (user white correction)

Target_Val : Target value for user correction (10bit output conversion value)

Vin:Input data (Before correction) Vout :Output data (After correction)

The corrected data is expressed in the following equation.

$$Vout = (Vin - Cal_bl) \times Target_val / (Cal_wh - Cal_bl)$$

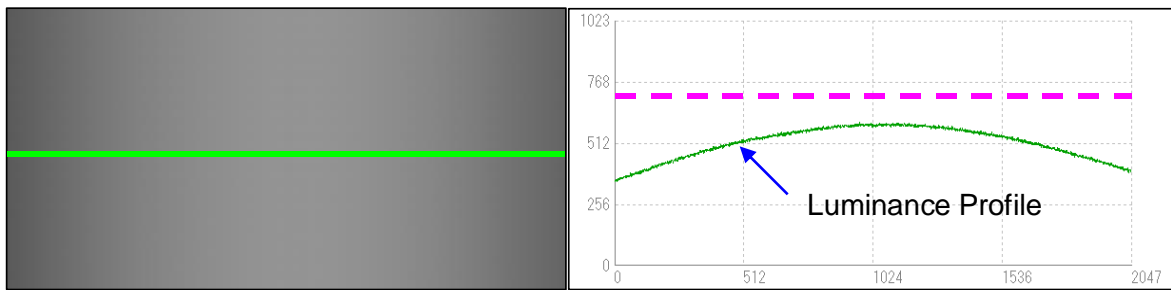

Image "before" user arbitrary pixel is corrected.

Green line is Luminance Profile

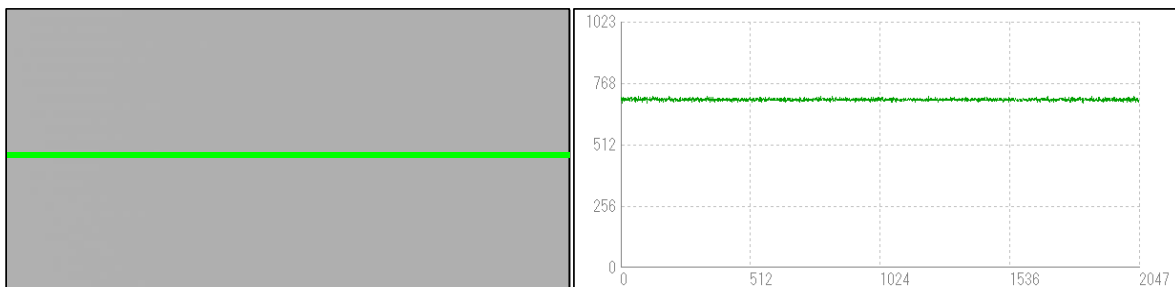

Image "after" user arbitrary pixel is corrected.

Green line is Luminance Profile

Figure 4-8-1 Waveform and image before and after bit correction

5 Basic Camera Setting Checks

5.1 Before Power On

Check whether there are any dents or scratches on the camera. There might have been damage to the camera's connectors or internals during transport.

- ① Check the pin assignments of the power cable(See figure 3-3-1 and table 3-3-1)
- ② Check that your network device supports 1000-Base T and Jumbo Frames.

Note:

If your device does not support the above, the network transfer speed will be adjusted to that of the slowest device. It may not be possible to capture images correctly due to data loss.

- ③ Check the devices' interconnectivity.

Note:

Use a CAT-5e or above LAN cable. In cases where cable length is long, CAT-6 or above is recommended.

Be sure that the network on which you connect your GigE camera is a dedicated network and not shared with any other data transmitting devices. Not only will image data not be correctly obtained, it may also interfere with the data transmission.

If you are connecting multiple cameras, check the camera output data rate and the network bandwidth, and set the packet delay appropriately. (See 4.4)

5.2 After Power On

- ① Using a GENiCAM™ compatible camera control software package (such as the included GigEGrab), execute camera discovery and confirm that the camera features can be read.
- ② Set the exposure mode (trigger mode), video output format, etc.
- ③ Start image capture with a GigE Vision® compatible viewer software package.

Note:

If you are using a firewall or security software, it may not be possible to receive image data. In this case either change the settings or stop the software.

6 Sensor Handling Instructions

6.1 Electrostatic Discharge and the Sensor

The CMOS sensors are susceptible to damage from electrostatic discharge and can deteriorate as a result. Take care when handling the sensor.

6.2 Protecting Against Dust, Oil and Scratches

The CMOS sensor window is part of the optical path and should be handled like other optical components with care. If you use the camera in a dusty area, prepare a dust-proof enclosure. Dust can obscure pixels, producing dark lines on the image.

6.3 Cleaning the Sensor Window

Dust: Can usually be removed by blowing the window surface using a compressed air blower.

Oil: Wipe the window with a lint-free cloth wiper moistened with ethyl alcohol carefully and slowly.

When there is dust or smudges on the sensor window, it appears in the same way as noise on the image. Please remove it appropriately.

7 Troubleshooting

The following pages contain several troubleshooting charts that can help you find the cause of problems users sometimes encounter.

7.1 No Image

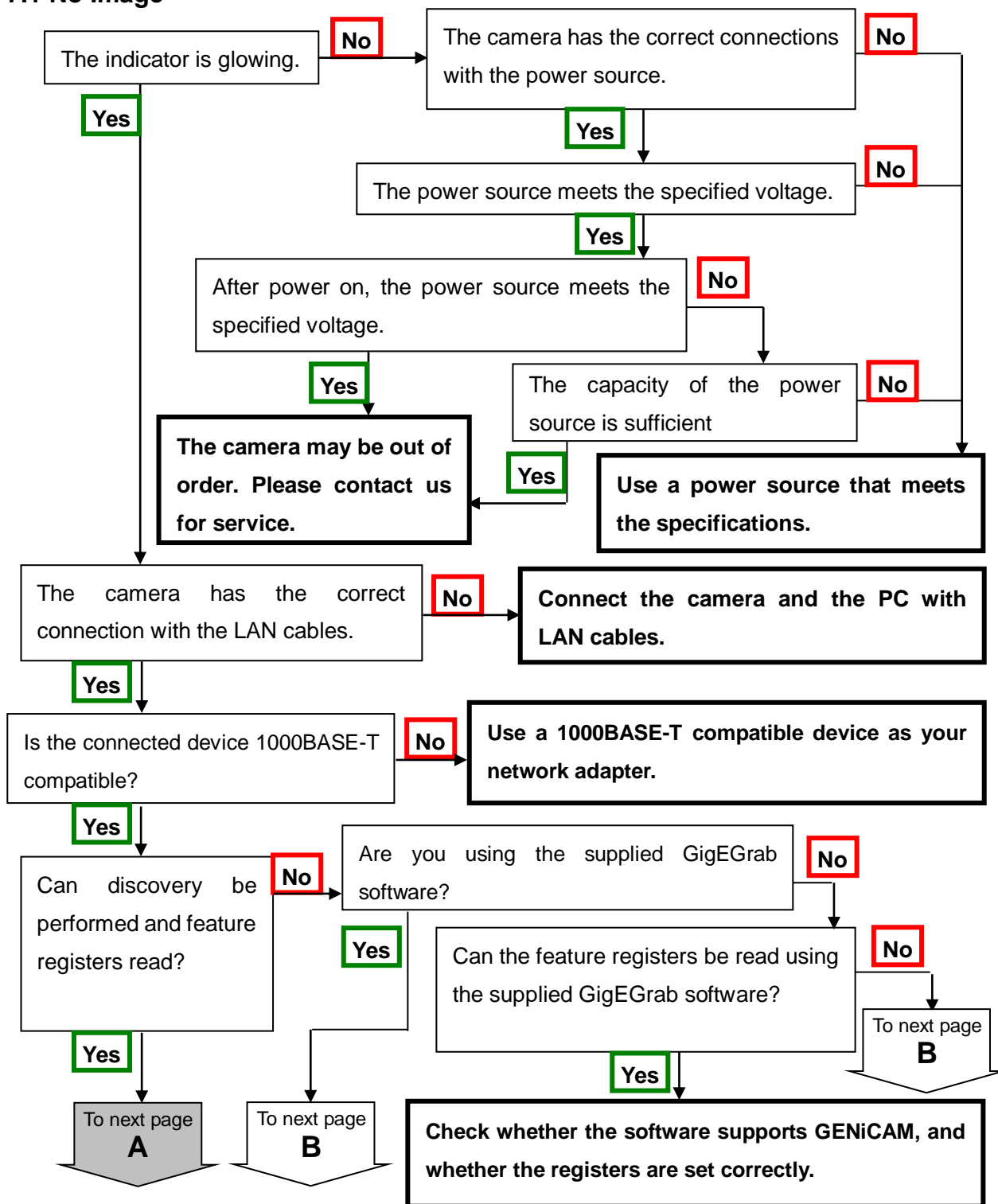

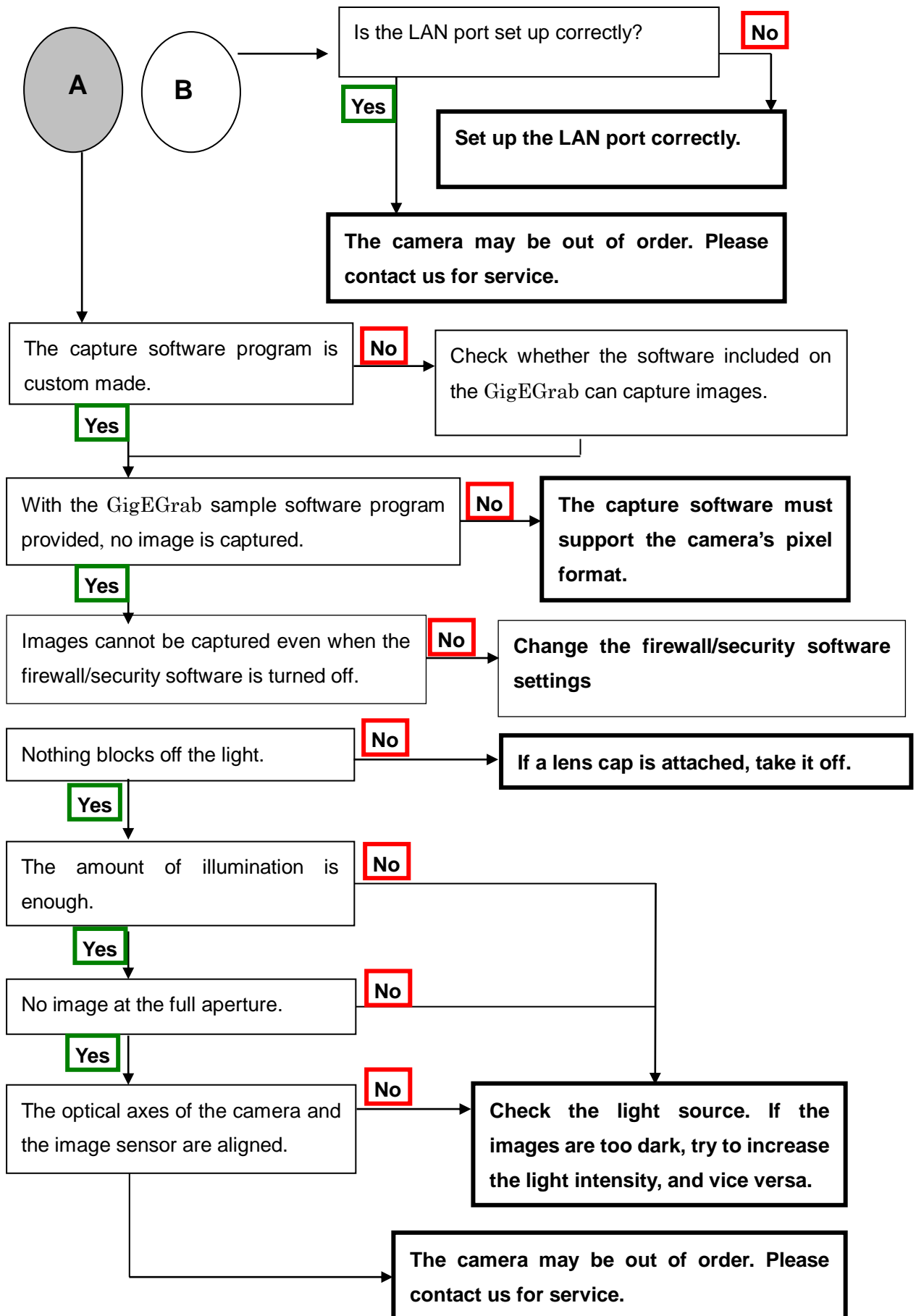

7.2 Noise on Image

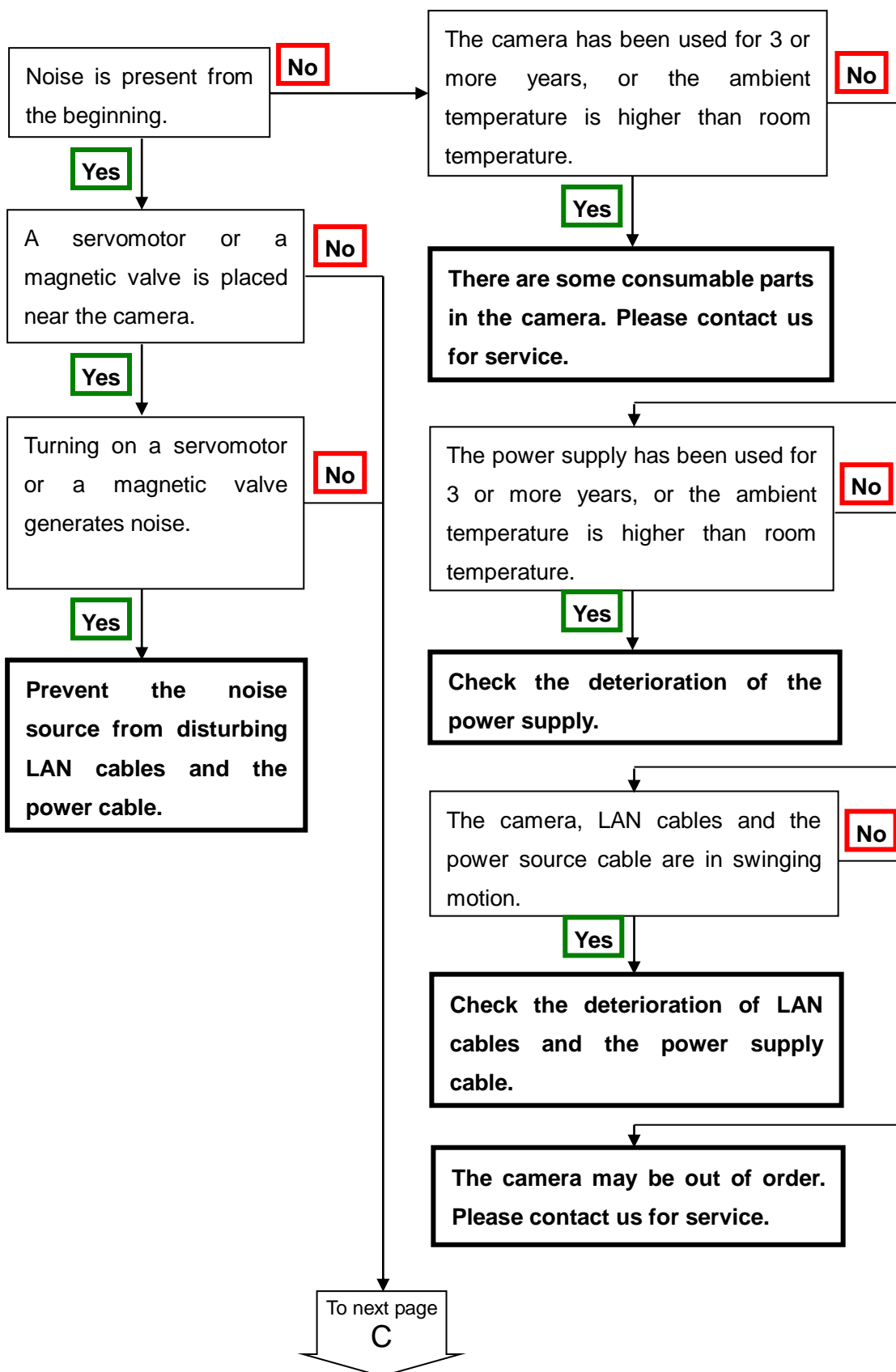

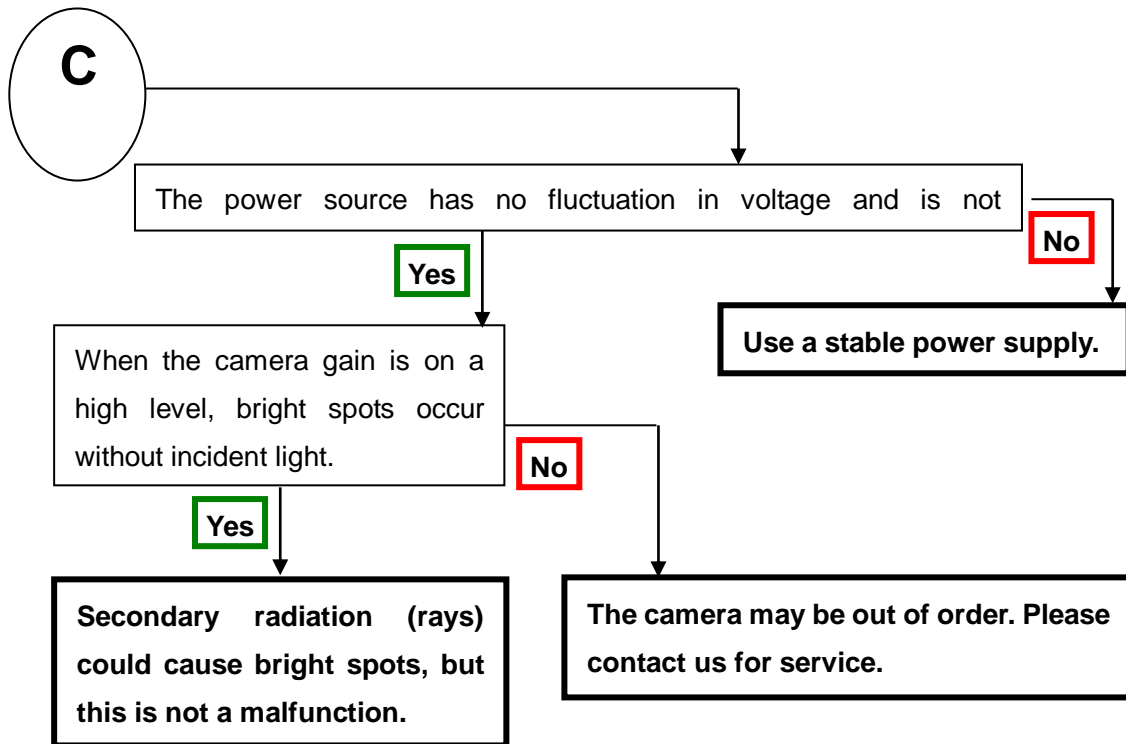

7.3 Camera becomes hot

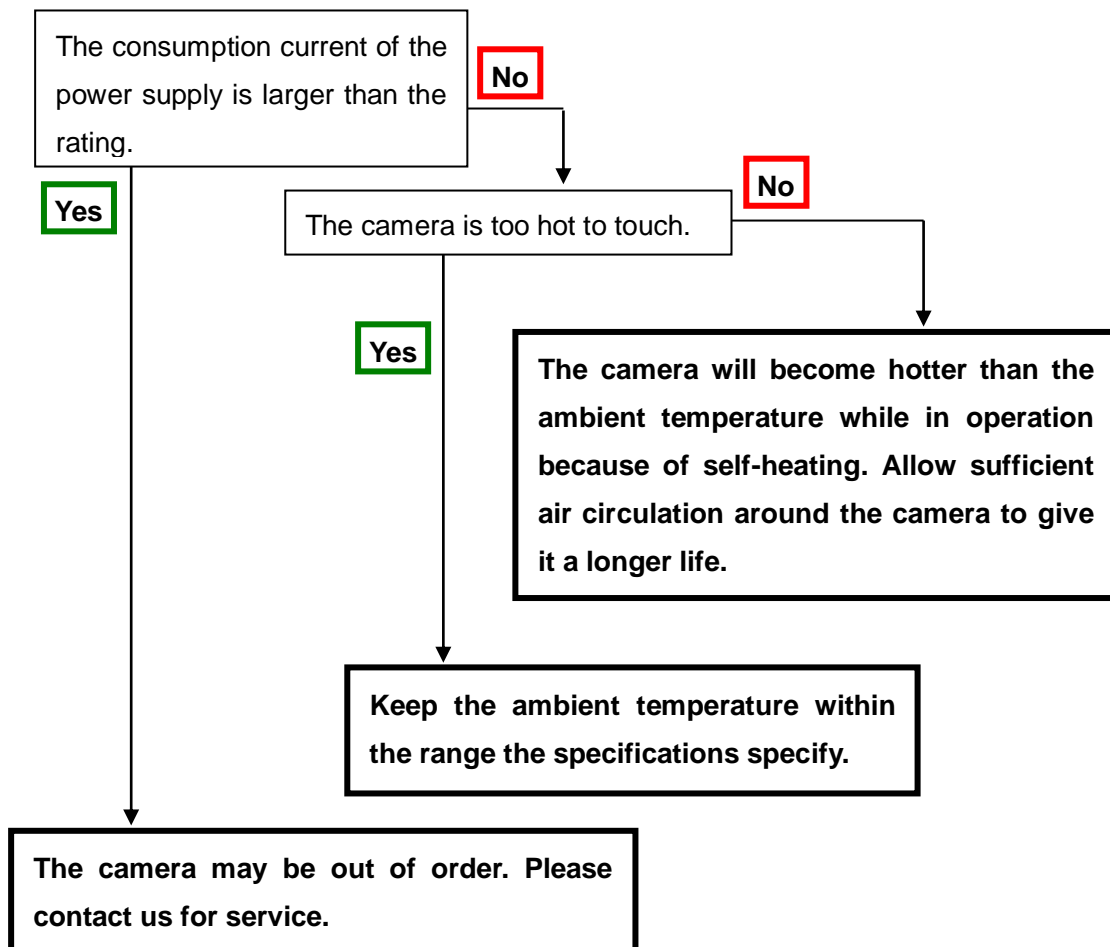

8 Others

8.1 Notice

- No part of this document may be reproduced in any form, in whole or in part, without the express written consent of NED.
- The contents of this document are subject to change without prior notice.
- Every care has been taken in the preparation of this User's Manual. If you should discover any errors or omissions, please notify your nearest NED representative.

8.2 Contact for support

Nippon Electro-Sensory Devices Corporation

Head Office

2-5-12, Itachibori, Nishi-Ku, Osaka 550-0012, Japan

Phone +81-6-6534-5300

Fax +81-6-6534-6080

Tokyo Office

Gibraltar Ohi BLD., Room No.402

1-45-2, Ohi, Shinagawa-Ku, Tokyo 140-0014, Japan

Phone +81-3-5718-3181

Fax +81-3-5718-0331

West Japan Office

Twin Square 1-8-28 Enokida, Hakata-Ku, Fukuoka, 812-0004, Japan

Phone +81-92-451-9333

Fax +81-92-451-9335

URL

<http://ned-sensor.co.jp/en>

E-Mail

sales@ned-sensor.com

8.3 Product Support

If there is a problem with your camera after checking it in accordance to the troubleshooting, turn off the power and call your NED representative.

When contacting us with a problem, please inform us of the status of the camera.

Revision History

Revision Number	Date	Changes
01	6 February 2019	Initial release
02	5 April 2019	Modified typographical error
03	16 Dec 2019	Change in the setting area of exposure time