

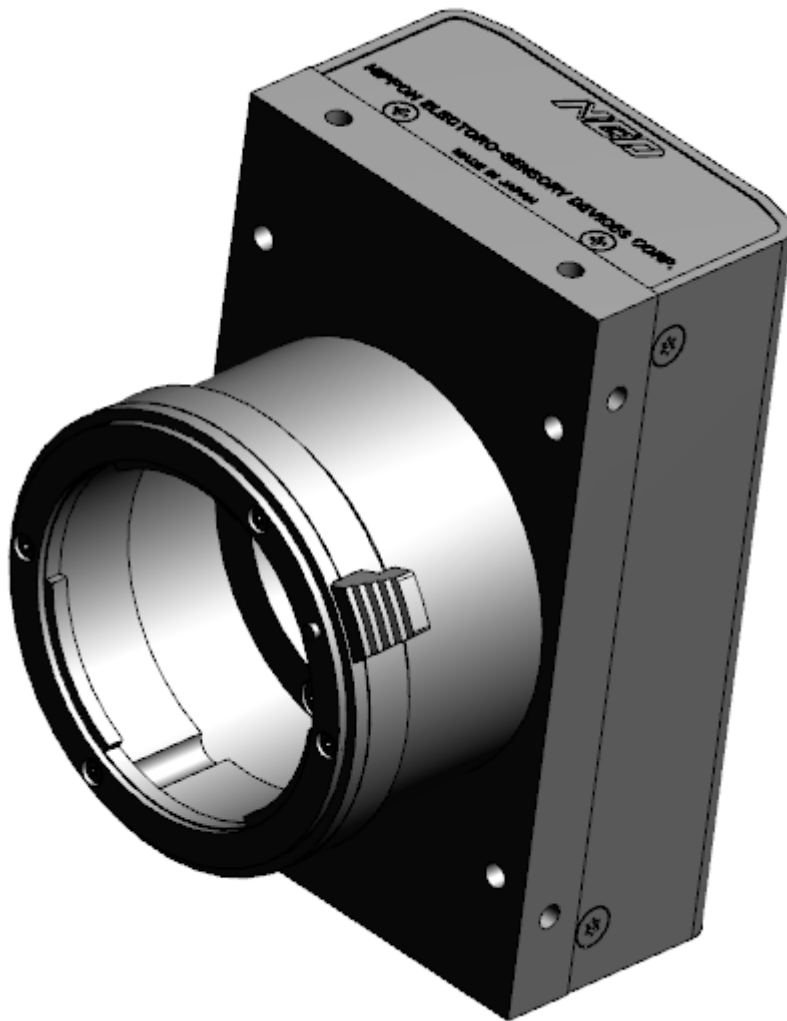

# User's Manual

Line Scan Camera

Model : RMSL8K39CL



***NIPPON ELECTRO-SENSORY DEVICES CORPORATION***

## For Customers in the U.S.A.

This equipment has been tested and found to comply with the limits for a Class A digital device, in accordance with Part 15 of the FCC Rules. These limits are designed to provide reasonable protection against harmful interference when the equipment is operated in a commercial environment. This equipment generates, uses, and can radiate radio frequency energy and, if not installed and used in accordance with the instruction manual, may cause harmful interference to radio communications. Operation of this equipment in a residential area is likely to cause harmful interference, in which case the user will be required to correct the interference at his or her own expense.

## For Customers in the EU

This equipment has been tested and found to comply with the essential requirements of the EMC Directive 2004/108/EC, based on the following specifications applied:

EU Harmonised Standards

EN55032:2015 Class A

EN55011:2009+A1:2010 Class A

EN61000-6-2:2005

\*Group 1 contains all ISM (Industrial, Scientific and medical) equipment in which there is intentionally generated and/or used conductively coupled radio-frequency energy which is necessary for the internal functioning of the Equipment itself.

\*Class A equipment is equipment suitable for use in all establishments other than domestic and those directly connected to a low voltage power supply network which supplies buildings used for domestic purposes.

### **Directive on Waste Electrical and Electronic Equipment (WEEE)**



Please return all End of Life NED products to the distributor from whom the product was purchased for adequate recycling and / or disposal. All costs of returning the Product to NED are borne by the shipper.

## Introduction

Thank you for purchasing NED's Line Scan Camera. We look forward to your continued custom in the future.

## For safety use

- ◆ For your protection, please read these safety instructions completely before operating the product and keep this manual for future reference.
- ◆ The following symbols appear next to important information regarding safe product handling.

 <b>Warning</b>	If the product is not handled properly, this may result in serious injury or possible death.
 <b>Caution</b>	If the product is not handled properly, this may result in physical injury or cause property damage.

## Safety precaution

### **Warning**

- ◆ Never disassemble or modify this product, unless otherwise specified to do so in this manual.
- ◆ When hands are wet, avoid handling this product and do not touch any of the connection cable pins or other metallic components.
- ◆ Do not operate this product in an environment that is exposed to rain or other severe external elements, hazardous gases or chemicals.
- ◆ If the product is not to be used for an extended period of time, as a safety precaution, always unplug the connection cable from the camera unit.
- ◆ If the product installation or inspection must be executed in an overhead location, please take the necessary measures to prevent the camera unit and its components from accidentally falling to the ground.
- ◆ If smoke, an abnormal odor or strange noise is emitted from the camera unit, first turn off power, then unplug the cable from the camera unit.
- ◆ This product is not intended for use in a system configuration built for critical applications.

## Instructions before use

- ◆ Only operate this product within the recommended environmental temperature range.
- ◆ Use only the specified power source and voltage rating.
- ◆ Do not drop this product. Avoid exposure to strong impact and vibrations.
- ◆ Install the camera unit in a well-ventilated environment, in order to prevent the camera from overheating.
- ◆ If the camera must be installed in an environment containing dust or other particles, take required measures to protect the camera unit from dust adhesion.
- ◆ Do not unplug the cable while power is being supplied to the camera unit. To prevent product damage, always shut down the power supply before unplugging the power cable.
- ◆ When the surface of the camera window becomes dirty due to dust or grime, black smudges appear in the displayed image. Use an air blower to remove the dust particles. Dip a cotton swab into ethanol alcohol and clean the camera window. Be careful not to scratch the glass.
- ◆ Use of non-infrared lighting such as a fluorescent lamp is recommended. If halogen lighting is employed, always install an infrared filter into your system configuration.
- ◆ Please note that exposure to long wavelength light outside of the sensors visible optical range can affect the image.
- ◆ Sensitivity may fluctuate depending on the spectral response level of the light source. In cases like this, changing the light source to one with a different spectral response level may reduce this problem. Moreover, this irregular sensitivity can be completely lost by using 4.11 pixel correction function. Please refer to 4.11 pixel correction function for details.
- ◆ Note that when the sensor is exposed to excessive quantities of light, blooming may occur, because this product does not have a special Anti-Blooming function.
- ◆ For stabilized image capturing, turn On the power supply and execute aging for ten to twenty minutes before actually using the camera unit.
- ◆ Do not share the power supply with motor units or other devices that generate noise interference.
- ◆ The signal ground (SG) and the frame ground (FG) are connected inside the camera unit. Design the system configuration so that a loop will not be formed by the ground potential differential.
- ◆ Do not disconnect the camera while rewriting an embedded memory.
- ◆ When you change exposure mode that is set at NED factory, input control signal (CC1) from the capture board.

## Product Warranty

### Warranty Period

- ◆ The product warranty period, as a general rule, is two years from purchase; however for detailed conditions please contact the sales representative for your region/country.
- ◆ However, in some cases due to the usage environment, usage conditions and/or frequency of use, this warranty period may not be applicable.

### Warranty Scope

- ◆ Product repair will be performed on a Return To Manufacturer basis. On-site maintenance will incur additional charges.
- ◆ If defects in material or workmanship occur during the warranty period, the faulty part will be replaced or repaired by us free of charge. Return shipping charges must be paid by the sender. However, the following cases fall outside of the scope of this warranty:
- ◆ The expired date of the warranty period on the product repaired or replaced during the warranty period of the original product is the same as the eapired date of the warranty period on the original product.

### Exclusions from Warranty Coverage

- ◆ We will under no circumstances assume responsibility for the following cases: damage caused by fire, earthquake, other acts of a third party, other accidents, negligent or intentional misuse by the user, or other usage under extraordinary circumstances.
- ◆ Damages (e.g. loss of business profits, business interruption, etc.) resulting from use or non-use.
- ◆ Damages caused by use other than as described in this document.
- ◆ Damages resulting from malfunction due to a connected device.
- ◆ Damages resulting from repairs or modifications performed by the customer.

### Fault Diagnosis

- ◆ As a general rule, in the first instance fault diagnosis should take the form of a telephone call or an email to enable us to assess the circumstances of the malfunction.
- ◆ However, depending on the customer's requests, we, or our agent, may require an additional fee for this service.

#### Exclusion of Liability for Compensation for Missed Opportunities

- ◆ Regardless of whether within the warranty period or not, our warranty does not cover compensation for missed opportunities for our customers, or our customers' customers, caused by a fault of our products, nor for damage to products other than our own, or related business.

#### Note about Product Usage

- ◆ This product has been designed and manufactured as a general-purpose product for general industry. In applications expected to be life-critical or safety-critical, the installer or user is requested to install double or triple failsafe systems.

#### Repair Service Outline

- ◆ The cost of dispatching engineers etc. for repair service is not included in the price of purchased and supplied goods. On request, arrangements can be made separately.

#### Scope of Repair Service

- ◆ The above assumes business dealings and usage to take place in the customer's region / country. In cases of business dealings and/or usage outside the customer's region/country, separate consultation is required.

**Table of Contents**

<b>1 Product Outline</b>	<b>10</b>
1.1 Features-----	10
1.2 Application -----	10
1.3 Image Sensor -----	12
1.4 Performance Specifications -----	12
<b>2 Camera Setting and Optical Interface</b>	<b>15</b>
2.1 Setting the Camera-----	15
2.2 Fixing the Camera -----	15
2.3 Optical Interface-----	17
<b>3 Hardware</b>	<b>18</b>
3.1 Camera Connection-----	18
3.2 Input / Output Connectors and Indicator-----	20
3.4 Power Supply -----	25
<b>4 Camera Control</b>	<b>26</b>
4.1 Flow of Camera Control -----	26
4.1.1 Command Overview	26
4.1.2 Camera Receiving Message (PC Sending Command)	26
4.1.3 Camera Sending Message (PC Receiving Message)	27
4.1.4 Camera Control Commands	28
4.2 Details on Commands-----	30
4.2.1 Setting Analog Gain	30
4.2.2 Setting Digital Gain	30
4.2.3 Setting Digital Offset	30
4.2.4 Setting Exposure Mode	31
4.2.5 Setting Scan Rate	31
4.2.6 Setting Exposure Time	31
4.2.7 Setting Pixel Correction mode	32
4.2.8 Setting Pixel Correction Level	32
4.2.9 Generating Test Pattern	33
4.2.10 Setting the Pixel Readout Direction	33
4.2.11 Setting Data Format	33

4.2.12 Setting Output Data Clock	33
4.2.13 Setting Tap Geometry	34
4.2.14 Setting Gamma correction	34
4.2.15 Memory Initializing (Initializing Camera Settings)	34
4.2.16 Memory Load	35
4.2.17 Memory Save	36
4.2.18 Capture black pixel correction data	36
4.2.19 Capture white pixel correction data	36
4.2.20 Returning the Cameras Settings to the its original status	37
4.2.21 Selecting the communication speed	37
<b>4.4 Startup</b>	<b>38</b>
<b>4.5 Saving and Loading Camera Settings</b>	<b>39</b>
<b>4.6 Serial Communication Settings</b>	<b>40</b>
<b>4.7 Video Output Format</b>	<b>40</b>
<b>4.8 Exposure Mode and Timing Chart</b>	<b>42</b>
4.8.1 Free Run Exposure Mode (Programming time setting)	42
4.8.2 External Trigger Exposure Mode (Trigger Edge)	43
4.8.3 External Trigger Exposure Mode (Trigger Level)	44
<b>4.9 Setting Offset</b>	<b>45</b>
<b>4.10 Setting Gain</b>	<b>46</b>
<b>4.11 Pixel Correction</b>	<b>48</b>
4.11.1 Command Settings	49
4.11.2 How to calibrate the camera	49
<b>4.12 Test Pattern</b>	<b>50</b>
<b>5 Confirming Camera Settings</b>	<b>51</b>
<b>5.1 Before Power-on</b>	<b>51</b>
<b>5.2 After Powemr-on</b>	<b>53</b>
<b>5.3 In Operation</b>	<b>55</b>
<b>6 Sensor Handling Instructions</b>	<b>56</b>
<b>6.1 Electrostatic Discharge and the Sensor</b>	<b>56</b>
<b>6.2 Protecting Against Dust, Oil and Scratches</b>	<b>56</b>
<b>6.3 Cleaning the Sensor Window</b>	<b>56</b>
<b>7 Troubleshooting</b>	<b>57</b>



**7.1 When there is no Image** -----57

**7.2 When Noise is present in the Image** -----59

**7.3 When the Camera becomes hot** -----61

**8 Others** **62**

**8.1 Notice** -----62

**8.2 Contact for support** -----62

**8.3 Product Support** -----63

8.3.1 Warranty card (attach a separate) 63

8.3.2 When you need to repair 63

**Revision History** **64**

# 1 Product Outline

## 1.1 Features

- High speed readout(340MHz)
- High resolution(3.5  $\mu$  8192 pixels)
- Choice of 2tap or 4tap with 8192 pixels on data format
- Choice of 8bit or 10bit on readout of all format
- Choice of 40MHz, 60MHz, 80MHz or 85MHz on data output clock speed
- Easy control of gain / offset with software outside the camera.
- Easy connection with a variety of frame grabber boards via Camera Link interface
- Single power source DC12V to 15 for operation
- Flat-field correction – minimizes lens vignetting, non-uniform lighting and sensor FPN and PRNU

## 1.2 Application

- Inspection of Transparent panels and PCBs
- Inspection of high speed moving objects
- Flat panel display inspection
- Inspection of glass and sheet-like objects
- Printed circuit board inspection
- This camera utilizes an Intelligent Transportation System
- Outdoor surveillance

Wide dynamic range prevents the camera from saturation caused by direct rays and specular reflection rays.

An example of Visual Inspection of PCBs is shown below.

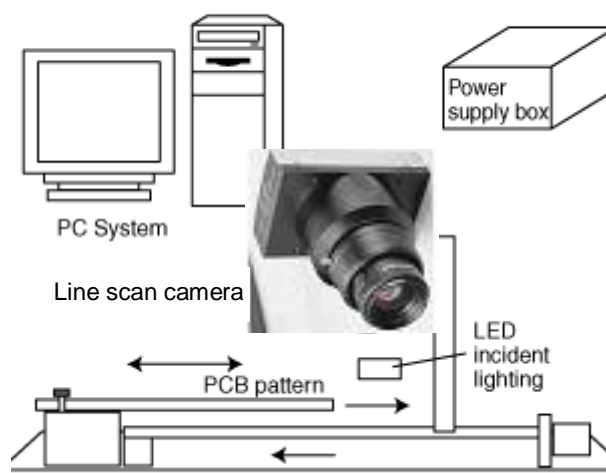

Figure 1-2-1 Visual Inspection of PCBs

### Applicable Work

COB, BGA and MCM printed circuit boards

### Performance

1. Maximum board size: 100mm×200mm
2. Resolution: 10 $\mu$ m
3. Inspection time: less than 30 seconds

### Unit Configuration

1. Camera: Line scan camera
2. Controller: Dedicated software for PC system
3. Size: L930 x D500 x H500 (mm)

### Applicable Fields

Inspection of patterns on film PCBs

### 1.3 Image Sensor

The camera adopts a CMOS sensor with the maximum data rate of 340MHz to acquire high quality images.

The pixels are  $3.5 \mu \text{m} \times 3.5 \mu \text{m}$ .

The camera outputs its 8192 pixels data through 85MHz-4Tap.

### 1.4 Performance Specifications

The Performance Specifications are shown in Table 1-4-1. It shows the data when the camera is operating at maximum scan rate, unless otherwise specified.

**Table 1-4-1 Performance Specifications**

Items	Specifications
	RMSL8K39CL
Number of Pixels	8192
Pixel Size H x V ( $\mu\text{m}$ )	3.5 x 3.5
Sensor Length (mm)	28.672
Spectral Responsivity (nm)	400 -1000 (Peak : 625, See Figure 1-4-1)
Data Rate (MHz)	340/320/240/160/170/160/120/80 (Selectable rate) (85x4/80x4/60x4/40x4/85x2/80x2/60x2/40x2)
Maximum Scan Rate (kHz) / ( $\mu\text{s}$ )	39.06 / 25.60 (at 340MHz data rate)
Saturation Exposure ( $\text{lx} \cdot \text{s}$ ) (typically)	0.071[Minimum Gain, Pixel Correction Initial Value, Daylight Fluorescent Light]
Responsivity (typically) [Minimum Gain, Pixel Correction Initial Value, Daylight Fluorescent Light] Visible Area (400~700nm)	50(V/[ $\text{lx} \cdot \text{s}$ ]) Analog 5V Conversion Sensitivity
Gain Adjustable Range *Analog Amplifier +Digital	Analog Amplifier : x 1 to x 10 (8 Steps) Digital : x 1 to x 2 (512 Steps)
Offset Adjustable Range *Digital	Digital : -127~127(0.5DN/STEP:8bit) -127~127(2.0DN/STEP:10bit)
FPN (Fixed Pattern Noise)	Typically 5 DN (without correction, at minimum gain) 2 DN (with correction, at minimum gain)

PRNU (Photo Response Non Uniformity)	Typically 20 DN (without correction, at minimum gain) 4 DN (with correction, at minimum gain)	
Random Noise	Typically 20 DN (peak value at minimum gain)	
Video output	Camera Link Medium Configuration (8or10bit/4tap) Camera Link Base Configuration (8or10bit/2tap)	
Control Input	CC1: External Trigger Signal, CC2-4: Not in use	
Connectors	Data/Controller	3M: MDR26 [Camera Link] x 2
	Power Supply	Hirose: HR10G(6Pin)
Lens Mount	Nikon F Mount	
Operating Temperature (°C) No Condensation	0 to 50	
Power Supply Voltage (V)	DC12 to 15 [±5%]	
Consumption Current (mA) (typically)	250	
Size W x H x D (mm)	60 x100 x 70	
Mass (g) (Camera only)	Approx. 380	
Additional Function	<ul style="list-style-type: none"> <li>1 Shading Correction</li> <li>2 Gain/Offset/Video Output(8bit/10bit) Adjustable</li> <li>3 Test Pattern Output On/Off</li> <li>4 Programmable Exposure Control</li> <li>5 Scan Direction Switching</li> <li>6 Selectable Data Rate</li> </ul>	

\*1) DN : Digital Number (10-bit : 0 -1023)

\*2) Measurements were made at room temperature.

The quantum efficiency is shown below.

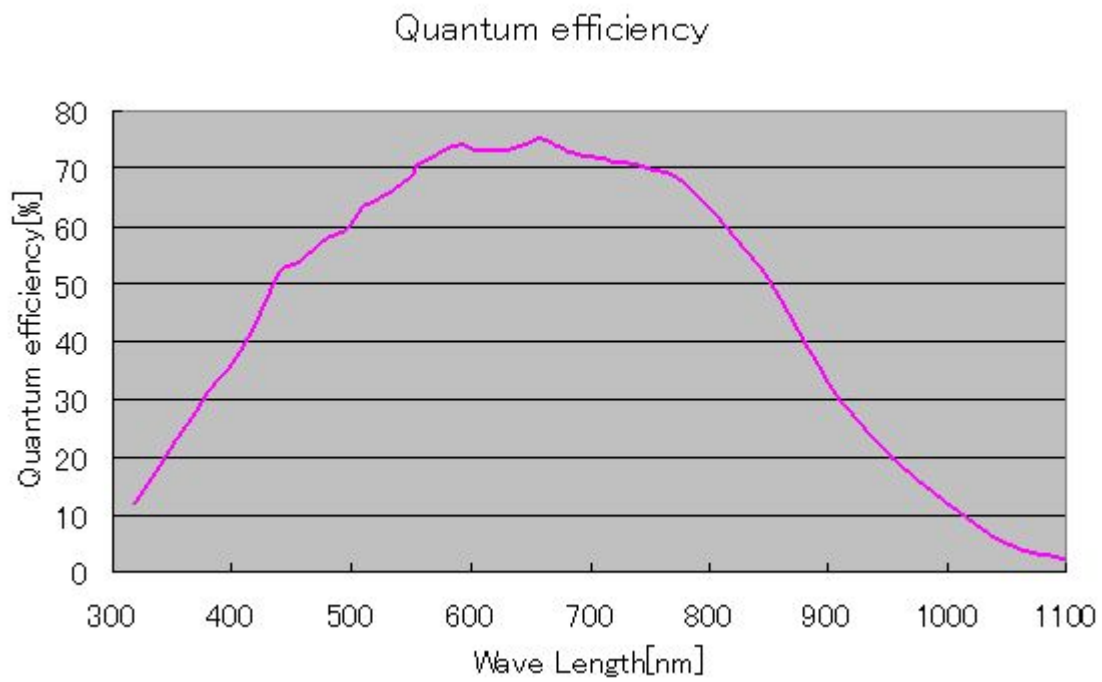

**Figure 1-4-1 Quantum efficiency**

## 2 Camera Setting and Optical Interface

### 2.1 Setting the Camera

Use the M4 screw holes or the tripod screw hole to set the camera.

An optional mounting base (sold separately) is available.

### 2.2 Fixing the Camera

- Use the M4 screw holes (4 on the front, 8 on the side) to set the camera.
- Or use the 1/4"-20UNC screw hole for a tripod (1 place at bottom).
- ◆ If using the front panel M4 mounting holes (4 places at front, 8 places at side), the screw length for fixing the camera at the front should be less than 8mm, and less than 6mm for the side.
- ◆ No X-, Y-axis orientation and tilt adjustment mechanism is available. Please prepare an adjustment mechanism if required.

The dimensions of the camera are shown below.  
 Nikon F mount

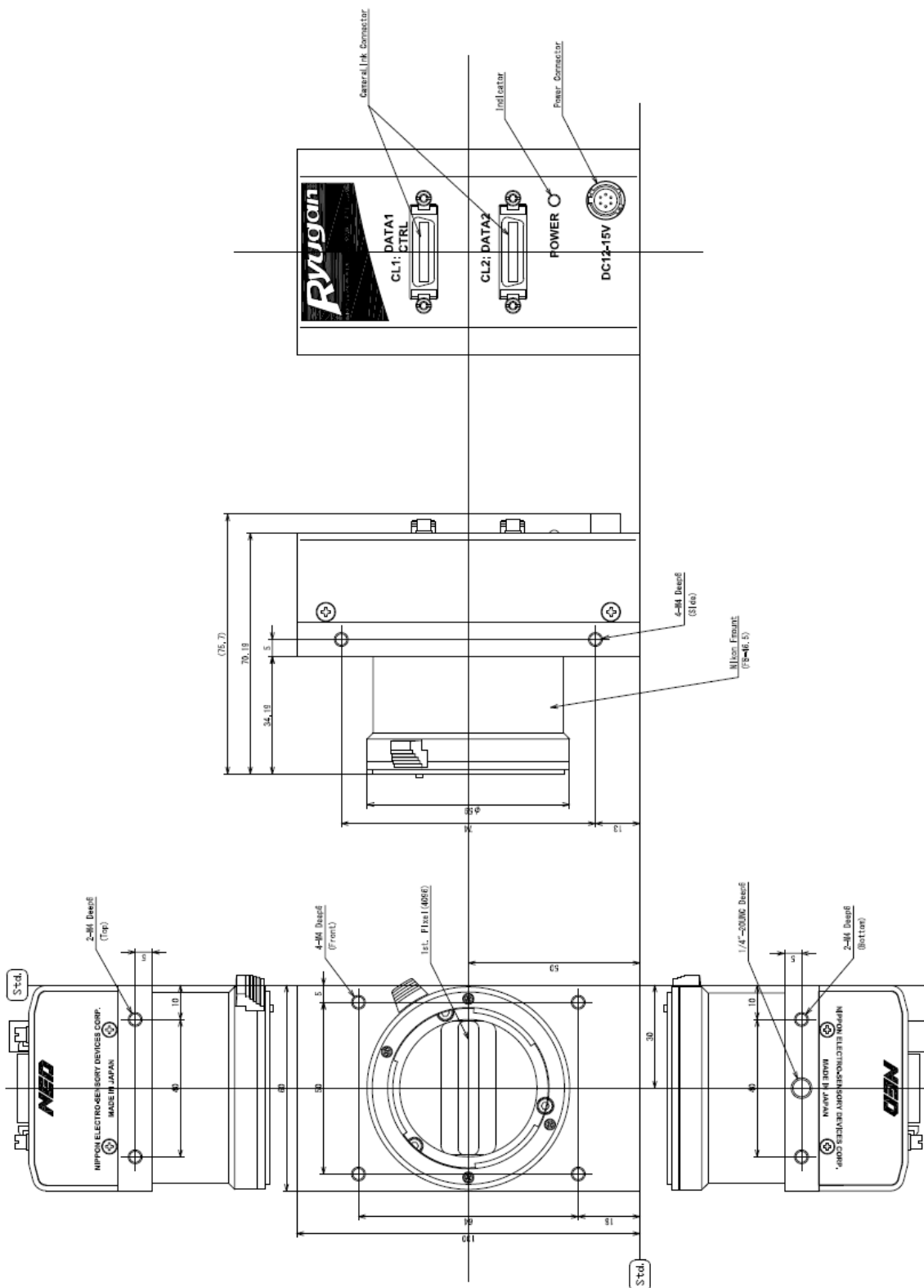

Figure 2-2-1 Dimensions of the Camera



## 2.3 Optical Interface

The camera is equipped with a Nikon F-mount.

The amount and wavelengths of light required to capture useful images depend on the intended use. Factors include the property, speed, the objects spectral characteristics, exposure time, the light source characteristics, the specifications of the acquisition system and so on.

The exposure amount (exposure time x light amount) is the most important factor in getting desirable images. Please determine the exposure amount after studying what is most important to your system.

Keep these guidelines in mind when setting up your light source:

- LED light sources are relatively inexpensive, provide a uniform field and longer life span compared to other light sources. However, they also require a camera with excellent sensitivity.
- Halogen light sources generally provide very little blue light but have high infrared light (IR) proportions.
- Fiber-optic light distribution systems generally transmit very little blue light relative to IR.
- Metal halide light sources are very bright but have a shorter life span compared to other light sources.

Generally speaking, the brighter the light sources, the shorter the life span.

CMOS image sensors are sensitive to infrared (IR). We recommend using daylight colour fluorescent lamps that have low IR emissions. If you use a halogen light source, to prevent infrared from distorting the images use an IR cutoff filter that does not transmit wavelengths.

### 3 Hardware

#### 3.1 Camera Connection

Use the camera in the following way:

- (1) Camera Link Medium Configuration cables must be used to connect the camera unit with the frame grabber board.
- ◆ Use two cables of the same length and the same manufacturer. Use asymmetric Camera Link Full Configuration cables and connect the camera with the connector labeled as "Camera side".
- (2) Connect the camera with the designated power supply.
- Use the designated power cable to connect the camera with the power source for the camera. Insert the plug end of the cable into the camera. Attach the opposite end (loose wires) to the power unit.
- ◆ Other than those above, a personal computer, a frame grabber board, a compatible lens, a lens mount, a light source and an encoder are necessary, depending on the situation.

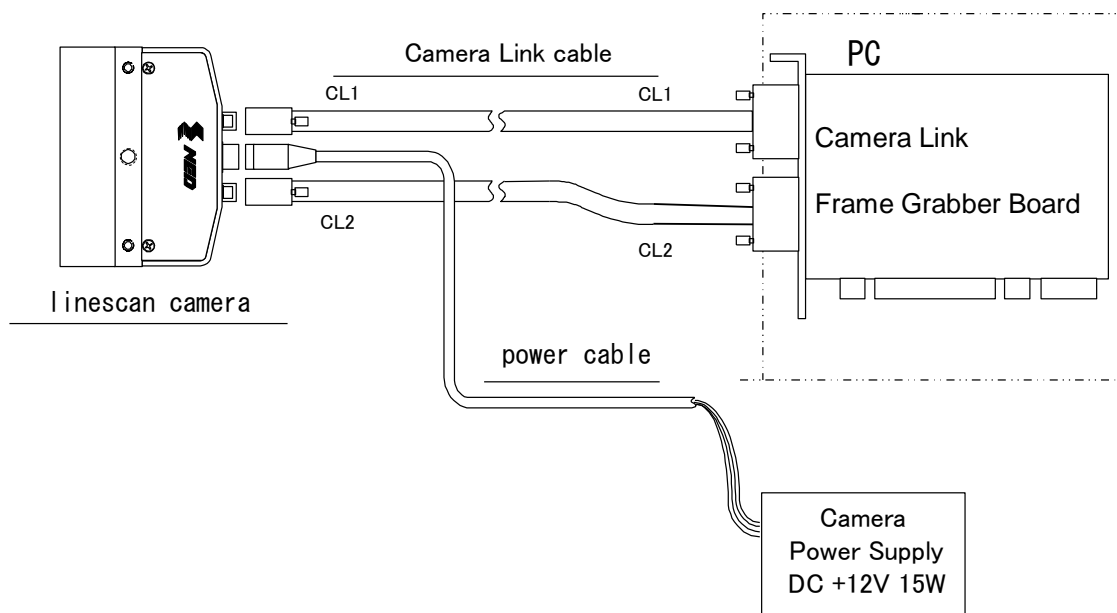

Figure 3-1-1 Connections between Camera and Frame Grabber Board and Power Supply

There are two connectors available for the Camera Link Medium Configuration board. Always check the frame grabber board specifications before making connections.

<Note: Choosing the appropriate Camera Link cable length >

According to the Camera Link Specification, the maximum cable length is 10m. But the maximum cable length to be able to transfer data depends on the type of cable performance and clock speed. The actual maximum transmission distance becomes less than 10m at faster clock speeds, though the transmission distance of 10m is feasible at slower clock speeds.

The following table shows values being calculated in accordance with the Camera Link Specification 2007.Version1.2, using a typical cable (14B26-SZLB-xxx-0LC from 3M) and frame grabber board (Solios from Matrox). Please choose the appropriate Camera Link cable type and length for your application. We recommend you perform a connection test in advance.

**Table 3-1-1 calculated value of maximum cable length**

Solios model	clock speed(MHz)	maximum cable length(m)
SOL 6M CL E* (20~66MHz)	40	9.8
	66	8.0
SOL 6M FC E* (20~85MHz)	75	7.6
	85	5.8

### 3.2 Input / Output Connectors and Indicator

The layout of input /output connectors and the LED indicator are as follows.

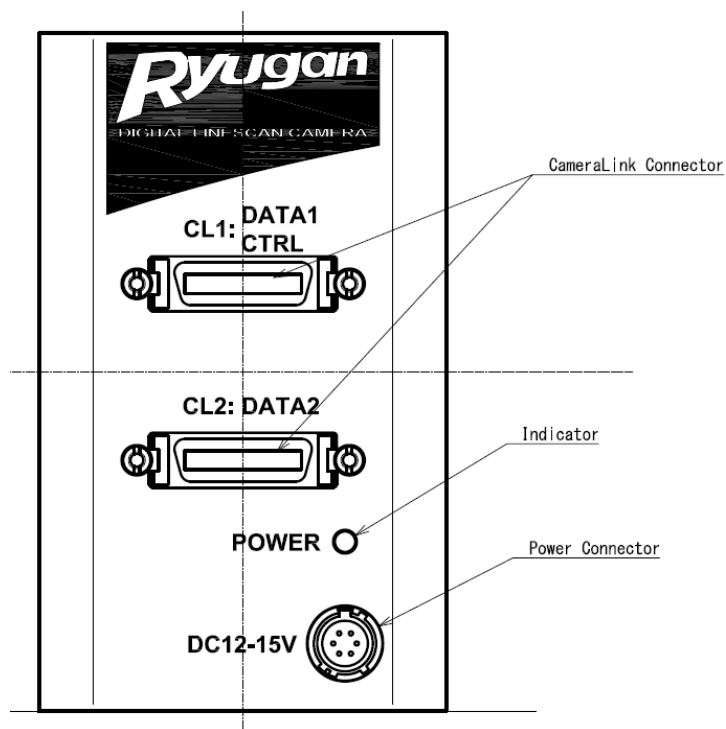

Figure 3-2-1 Input/Output Connectors and Indicator

### 3.3 Connectors · Pin Assignments · Cables

This camera adopts Medium Configuration of Camera Link interface standards. Figure 3-3-1 shows the interface for the camera and a typical implementation for the frame grabber interface.

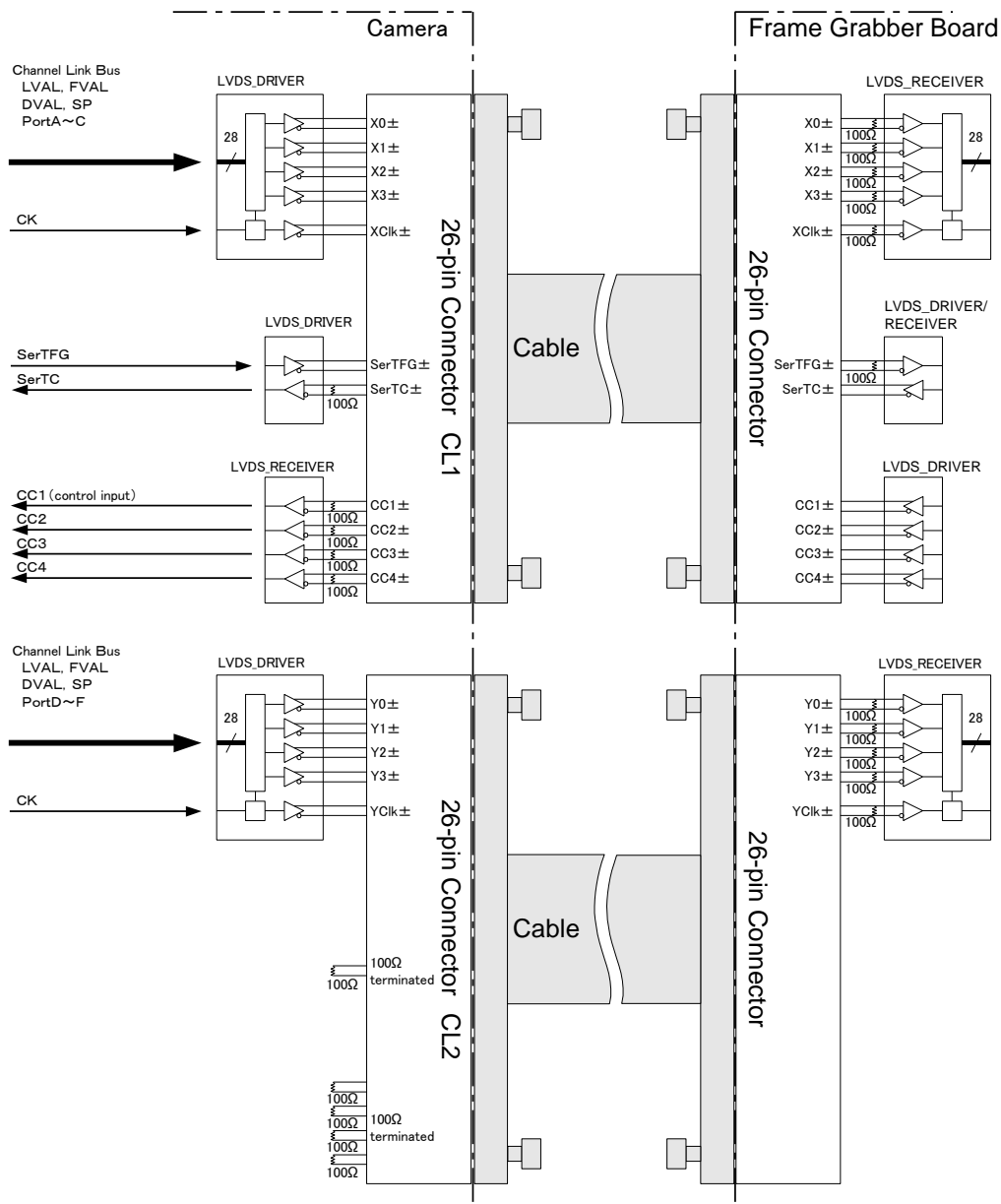

Figure 3-3-1 Camera / Frame Grabber Interface (Base, Medium)

- ◆ Set the LVDS, Channel Link driver side to 100-ohm termination.
- ◆ Do not make the receiver side of LVDS open but set the logic to H or L, even if not used.



**Figure 3-3-2 Circuit of LVDS**

The camera has 26-pin connectors for control signals of Camera Link, data signals and serial communications. The camera also has a 6-pin HIROSE connector for power supply.

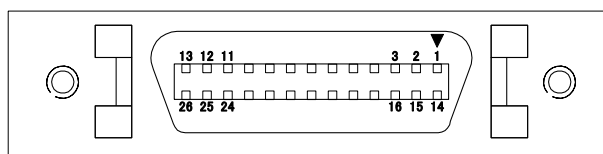

**Figure 3-3-3 Camera Link Connector**

- Locking screw type

**Table 3-3-1 Camera Link Connector (26-pin Connector) pin assignments**

CL1(Base Configuration)

No	NAME	No	NAME	I/O
1	Inner Shield	14	Inner Shield	
2	X0-	15	X0+	Out
3	X1-	16	X1+	Out
4	X2-	17	X2+	Out
5	Xclk-	18	Xclk+	Out
6	X3-	19	X3+	Out
7	SerTC+	20	SerTC-	In
8	SerTFG-	21	SerTFG+	Out
9	CC1-	22	CC1+	In
10	CC2+	23	CC2-	In
11	CC3-	24	CC3+	In
12	CC4+	25	CC4-	In
13	Inner Shield	26	Inner Shield	

CL2(Medium Configuration)

No	NAME	No	NAME	I/O
1	Inner Shield	14	Inner Shield	
2	Y0-	15	Y0+	Out
3	Y1-	16	Y1+	Out
4	Y2-	17	Y2+	Out
5	Yclk-	18	Yclk+	Out
6	Y3-	19	Y3+	Out
7	100Ωterminated	20	100Ωterminated	
8	Open	21	Open	
9	100Ωterminated	22	100Ωterminated	
10	100Ωterminated	23	100Ωterminated	
11	100Ωterminated	24	100Ωterminated	
12	100Ωterminated	25	100Ωterminated	
13	Inner Shield	26	Inner Shield	

- **Explanation of Signals**
  - Inner Shield : Shield cable (GND)
  - X0+,X0-...X3+,X3- : Data output (Channel Link)
  - Xclk+,Xclk- : Clock output for above data output synchronization (Channel Link)
  - Y0+,Y0-...Y3+,Y3- : Data output (Channel Link)
  - Yclk+,Yclk- : Clock output for above data output synchronization (Channel Link)
  - SerTC+, SerTC- : Serial data input (LVDS)
  - SerTFG+, SerTFG- : Serial data output (LVDS)
  - CC1+,CC1- : External synchronous signal input (LVDS)
  - CC2+,CC2- : Not in use (LVDS)
  - CC3+,CC3- : Not in use (LVDS)
  - CC4+,CC4- : Not in use (LVDS)
- **Camera Link compatible cable**
  - MDR-MDR 3M : 14B26-SZLB-xxx-0LC by or equivalent
  - SDR-MDR 3M : 1MF26-L560-00C-xxx by or equivalent
  - SDR-SDR 3M : 1SF26-L120-00C-xxx by or equivalent
- ◆ **To avoid uncoupling of the cable connectors during power on, make sure to clamp them with the locking screws.**
- ◆ **Do not unplug the cables while power is being supplied to the camera.**

This camera uses 6-pin round shape push-pull lock type connector for the Power Supply. Acceptable Cable (Acceptable plug):DGPSH -10 (HIROSE : HR10G-7P-6S)

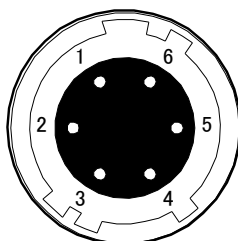

**Figure 3-3-4 Power Supply Connector (HIROSE: HR10G-7R-6PB)**

**Table 3-3-2 Pin Assignment of Power Supply Connector**

No	NAME	Colour of Cable
1	DC12 –15V	White
2	DC12 –15V	Red
3	DC12 –15V	—
4	GND	Green
5	GND	Black
6	GND	—

Note:

The cable colour in the table describes the compatible cable DGPSH-10.



### 3.4 Power Supply

The camera requires a single power supply (DC+12 to +15V). The indicator (GreenLED) blinks when power is supplied. After a short period, it changes to a solid light, indicating that the camera is operational.

**Notes:**

- 1) When selecting a power source, choose one with the capacity to allow for inrush current. (7.5 W or more recommended)
- 2) Insert the cable plug securely until it locks into position. This is to prevent the connector from coming loose during power transmission.
- 3) Take the necessary countermeasures in the electric supply line for lightning surge protection, if the camera is used in the area where lightning strikes often occur.
- 4) Do not share the power supply and ground connection with the apparatus such as the inverter controlled motor units or other devices that generate noise interference to avoid the failure and malfunction of the camera. Place the camera far away from the apparatus generating noise. Do not arrange the signal cables and the power supply cable for camera adjacently.
- 5) If the lamp fails to illuminate even after power is switched on, turn off power immediately. Inspect wiring. Check the voltage and capacity of the supplied power source.
- 6) It is recommended that the shield processing of the power cable to be connected with GND on the power supply side.

## 4 Camera Control

The camera can be controlled through the serial communication. Two methods can be used to change the camera's parameters. The first approach is to change parameters using NCamCtrl(Camera control software). Or you can also change the parameters directly from your application by using binary read/write commands to set values in the camera register.

Once the camera has been set up according to your requirements, the camera can be used to read data without need of controlling it via the serial interface.

### 4.1 Flow of Camera Control

#### 4.1.1 Command Overview

The serial interface uses a simple ASCII-based command.

- Communication begins when the computer sends control commands to the camera.
- The camera receives and interprets the computer commands and then executes control operations accordingly.
- Transmission ends when the camera returns the analyzed results of the control commands to the computer.
- ◆ Always allow the previous transmission to end before starting the next transmission. (Only one command can be sent per transmission.)

#### 4.1.2 Camera Receiving Message (PC Sending Command)

- Format    CMD CR
- Format    CMD □ VAL CR
- Format    CMD □ VAL □ CR

CMD: Control text (3 Bytes) Use 3 lowercase letters only. No numerals allowed.

CR: Carriage Return (0x0D)

□: Space (0x20) or Comma (0x2C)

VAL: Setting value (decimal, maximum 5 digits)

<Example>

gax □ 0 CR

### 4.1.3 Camera Sending Message (PC Receiving Message)

- Format >R CR >[SB] CR EOT
- Format (for "sta" command) >OK CR >[MEM] CR >sta CR EOT

> : Results start text (0x3E)  
 R: Camera receive command analyzed results  
 [SB] : Camera receive command send back  
 [MEM] : Memory data readout value  
 CR: Separated text (0x0D)  
 EOT: Send command all text End text (0x04)

<Example>

>OK CR >gax 0 CR EOT

**Table 4-1-3-1 Error Messages**

Camera Response	Meaning
OK	Camera executed command
CMD ERR!	Command is not valid
CMD OVR ERR!	Command text line is too long
VAL ERR!	Parameter accepted was outside of specified
MEM ERR!	Memory error

#### 4.1.4 Camera Control Commands

Table 4-1-4-1 shows the list of Camera Control Commands.

**Table 4-1-4-1 List of Camera Control Commands**

Control Item	CMD	VAL	Control Description	factory settings
Analog Gain	gax	0 to 7	x1.00...x10.00(8step)	0
Digital Gain	gdx	0 to 511	x1...x2(x0.003906/step)	0
Digital Offset	odx	-127 to 127	-63...63(0.5 DN/step at 8-bit) -254...254(2 DN/step at10-bit)	0
Exposure Mode	inm	0 /1/2	Free Run / Ext Edge / Ext Level	0
Scan Rate	prd	See4.8	See4.8	8183
Exposure Time	expo	See4.8	See4.8	120000
Pixel Correction Setting	ffcm	0/1/2/3/ 4/5	Correction Off / factory black correction + factory white correction / factory black correction + any white correction / unused / any black correction + factory white correction / any black correction + any white correction, Correction level target value (in 10- bits)	0
Pixel Correction Target Value	ffct	1 to 1023	Pixel Correction Target Value (10bit DN)	800
Test Pattern	tpn	0 /1	Off/On	
Scanning Direction	rev	0 /1	0 : Forward / 1 : Reverse	
Pixel Format	pxf	0 /1	0 : mono8 / 1 : mono10	
CameraLink Output Clock	clkcl	85/80/ 60/40	85:85MHz / 80:80MHz / 60:60MHz / 40:40MHz	85
Output Tap Format	tapg	0/1/2	0: GenICam_2X2E / 1: GenICam_1X2	0
Gamma Correction Setting	gamma	250 to 4000	$\gamma = \text{Val} / 1000$ Example : If Val=450, $\gamma = 450 / 1000 = 0.45$	1000
Memory Initializing	rst		Reset to factory settings	

Memory Load	rfd		Readout setup data in memory	
Memory Save	sav		Store present setup data in memory	
Capture black pixel correction data	blk		Obtain any black correction data and save it in memory	
Capture white pixel correction data	wht		Obtain any white correction data and save it in memory	
Operation Status Readout	sta		Returns the current camera settings.	
Communication speed selection	sbaud	9600/ 115200	9600(at factory setting/ 115200bps	9600

## 4.2 Details on Commands

### 4.2.1 Setting Analog Gain

Sets analog gain in 21 steps between x1 and x11.2.

- Format            CMD□VAL CR
- CMD              gax
- VAL              0 (x1) to 7 (x10.0)

<Example>

gax□2 CR (Setting analog gain 2(x3.0))

>OK

>gax 2

### 4.2.2 Setting Digital Gain

Sets digital gain in 512 steps between x1 and x2.

- Format            CMD□VAL CR
- CMD              gdx
- VAL              0(x1) to 511(x2)

<Example>

gdx□255 CR (Setting digital gain 255(1023/(1023-255)=x1.33))

>OK

>gdx 255

### 4.2.3 Setting Digital Offset

Sets digital offset -127 to +127(8-bit:0.5DN/Step 10-bit:2DN/Step)

- Format            CMD□VAL CR
- CMD              odx
- VAL              -127 to 127

<Example>

odx□10 CR (8/10bit Setting digital offset +5/+20DN(8-bit/10-bit))

>OK

>odx 10

#### 4.2.4 Setting Exposure Mode

Sets the exposure mode.

- Format      CMD□VAL CR
- CMD                inm
- VAL                0,1,2

<Example>

```
inm□0 CR (Setting the exposure mode free run)
>OK
>inm 0
```

#### 4.2.5 Setting Scan Rate

Sets the Scan Rate.

- Format      CMD□VAL CR
- CMD                prd
- VAL                See 4.8 Exposure Mode and Timing Chart

<Example>

```
prd□30000 CR
>OK
>prd 30000
```

#### 4.2.6 Setting Exposure Time

Sets the exposure time.

- Format      CMD□VAL□ CR
- CMD                expo
- VAL                See 4.8 Exposure Mode and Timing Chart

<Example>

```
expo□7000 CR
>OK
>expo 7000
```

Notes :

The relation between the scan period and the exposure time is as follows.

Scan period (reciprocal number of the scan rate)

> Exposure time + blanking (fixation time)

- Setting the scan rate

The camera coordinates the exposure time automatically if the inequality mentioned as above is not met when you set the scan rate (reciprocal

number of the scan period) with the camera which the exposure time was already set at.

This automatic coordinated exposure time is displayed by pushing the present value acquisition button.

● **Setting the exposure time**

The camera coordinates the scan rate (reciprocal number of the scan period) automatically if the inequality mentioned as above is not met when you set the exposure time with the camera which the scan rate was already set at.

This automatic coordinated scan rate is displayed by pushing the present value acquisition button.

#### 4.2.7 Setting Pixel Correction mode

Sets pixel correction mode.

- Format                    CMD□VAL□ CR
- CMD                      ffc
- VAL                      0, 1, 2, 3, 4, 5 (0: Correction Off, 1: factory black correction + factory white correction, 2: factory black correction + any white correction, 3: unused, 4: any black correction + factory white correction, 5: any black correction + any white correction)

<Example>

```
ffcm□1 CR (for factory black correction + factory white correction, Correction level 900)
>OK
>shc 1,900
```

#### 4.2.8 Setting Pixel Correction Level

Sets pixel correction.level

- Format                    CMD□VAL□ CR
- CMD                      ffct
- VAL                      0 to 1023 (Setting correction level:10-bit)

<Example>

```
ffct□900 CR (Correction level 900)
>OK
>ffct 900
```



### 4.2.9 Generating Test Pattern

Generates test pattern.

- Format                    CMD□VAL CR
- CMD                     tpn
- VAL                     0,1 (0:Image data, 1: Test pattern)

<Example>

```
tpn□1 CR (Generating test pattern)
>OK
>tpn 1
```

### 4.2.10 Setting the Pixel Readout Direction

Sets the pixel readout direction.

- Format :                 CMD□VAL CR
- CMD :                  rev
- VAL :                  0,1 (0:Forward, 1:Reverse)

<Example>

```
rev□1 CR (Reverse)
>OK
>rev 1
```

### 4.2.11 Setting Data Format

Sets the data format of output signals.

- Format                    CMD□VAL CR
- CMD                     pfm
- VAL                     0,1 (0: 8-bit / 1: 10-bit)

<Example>

```
pfm□0 CR (8-bit output)
>OK
>pfm 0
```

### 4.2.12 Setting Output Data Clock

The data format of the camera output signal is linearly fixed.

- Format                    CMD□VAL CR
- CMD                     clkcl
- VAL                     85,80,60,40 (85:85MHz,80:80MHz,60:60MHz,40:40MHz)

<Example>

```
clkcl 40 CR (40MHz output data clock)
>OK
>clkcl 40
```

#### 4.2.13 Setting Tap Geometry

The data format of the camera output signal is linearly fixed.

- Format            CMD VAL CR
- CMD             tapg
- VAL             0,1 (0:GenlCam\_2X2E,1:GenlCam\_1x2)

<Example>

```
tapg 0 CR (GenlCam_2x2E)
>OK
>tapg 0
```

#### 4.2.14 Setting Gamma correction

Switch the gamma correction settings.

- Format    CMD VAL CR
- CMD       gamma
- VAL    250~4000( $\gamma = \text{VAL}/1000$  it is effective)

<Example>

```
gamma 450 CR (0.45 at gamma correction setting)
>OK
>gamma 450
```

#### 4.2.15 Memory Initializing (Initializing Camera Settings)

Reset the flash memory to the factory default.

- Format    CMD CR
- CMD       rst

<Example>

```
rst CR
>OK
>Type=RMSL8K39CL
>Ver.=1.13_0x0253
>Serial=3
>gax 0
```

```
>gdx 0
>odx 0
>inm 0
>prd 8183
>expo 120000
>ffcm 1
>ffct 800
>tpn 0
>rev 0
>pxf 0
>clkcl 85
>tapg 0
>gamma 1000
>logmode 1
>rst
```

#### 4.2.16 Memory Load

Reads out the camera settings from the flash memory.

- Format      CMD CR
- CMD                rfd

<Example>

```
rfd CR
>OK
>Type=RMSL8K39CL
>Ver.=1.13_0x0253
>Serial=3
>gax 0
>gdx 0
>odx 0
>inm 0
>prd 8183
>expo 120000
>ffcm 1
>ffct 800
>tpn 0
>rev 0
>pxf 0
>clkcl 85
>tapg 0
```

```
>gamma 1000
>logmode 1
>rfd
```

#### 4.2.17 Memory Save

Stores the current camera settings in the flash memory.

- Format      CMD CR
- CMD               sav

<Example>

```
    sav CR
>OK
>sav
```

#### 4.2.18 Capture black pixel correction data

Save the user arbitrary black pixel correction data of analog gain in flash memory. The data at each step of analog gain can be saved. This command can be used in at perfect dark of the camera. See **4.2.7 Setting Pixel Correction mode**

- Format      CMD CR
- CMD               blk

<Example>

```
    blk CR
>OK
> blk
```

#### 4.2.19 Capture white pixel correction data

Save the user arbitrary white pixel correction data of analog gain in flash memory. The data at each step of analog gain can be saved. .

- Format      CMD CR
- CMD               wht

<Example>

```
    wht CR
>OK
> wht
```

#### 4.2.20 Returning the Cameras Settings to the its original status

Returns the current camera settings.

- Format            CMD CR
- CMD             sta

<Example>

```
sta CR
>OK
>Type=RMSL8K39CL
>Ver.=1.13_0x0253
>Serial=3
>gax 0
>gdx 0
>odx 0
>inm 0
>prd 8183
>expo 120000
>ffcm 1
>ffct 800
>tpn 0
>rev 0
>pxf 0
>clkcl 85
>tapg 0
>gamma 1000
>logmode 1
>sta
```

#### 4.2.21 Selecting the communication speed

Selects the baud rate 9600bps or 115200bps to set the speed of communication with PC.

- Format            CMD VAL CR
- CMD             sbaud

<Example>

```
sbaud 115200
>OK
>sbaud 115200
```

### 4.3 Digital Processing flow in FPGA

The digital processing flow in FPGA is shown below.

#### FPGA Processing block diagram

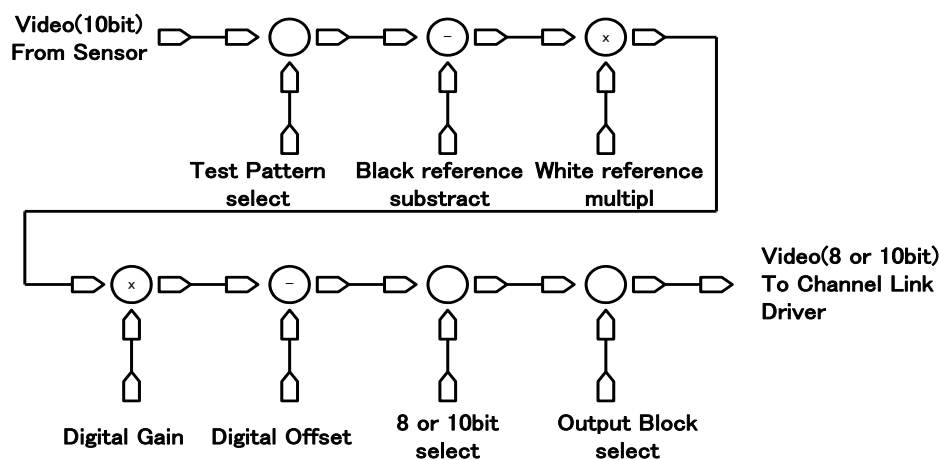

In Test Pattern mode, Black / White reference and Digital Gain /Offset will be skipped.

Figure 4-3-1 FPGA Processing Block Diagram

### 4.4 Startup

After turning on, the camera run a startup procedure before it starts getting images and outputting data. It takes about ten seconds.

The startup procedure is as follows.

- (1) The camera hardware initializes.
- (2) Reads out the latest camera settings from the flash memory.  
(User settings if any or factory default settings)
- (3) Set up the camera with the setting value from the flash memory.

After those sequences, the camera is ready to get images and output data.

## 4.5 Saving and Loading Camera Settings

The camera settings data is saved in the internal memory (flash memory) and is loaded from the memory when turning on the power supply or loading (sending the “rfd” command).

- The number of times the flash memory can be rewritten will vary depending on actual operational conditions. After turning on the power supply, the camera always checks the memory status. If the data is not within the designated range due to a malfunction or other type of trouble, the memory will be automatically reset to the factory settings.

- ◆ If the camera power is disconnected while rewriting the memory, the whole data saved in the memory will be deleted.

As it takes several seconds to rewrite the memory, do not disconnect power supply before receiving the answer from the camera.

Commands for rewriting the memory are as follows.

- Reset to factory settings (rst)
- Store present setup data in memory (sav)
- Store pixel correction data in memory (wht)

- ◆ When changing the factory setting exposure mode, be sure to send the control input signal (CC1). If you do not send CC1 or sending control input signals are out of the designated range, you cannot get images and cannot change the settings. See 4.8.2 and 4.8.3.

**Table 4-5-1 Camera Operation Mode and Control Input**

Camera operation mode (Exposure mode)	Control input (from frame grabber board)
Free Run (Programmable time setting) (Factory Setting)	Not in use
Ext Edge (External trigger edge + Programmable time setting)	External trigger (CC1) is required
Ext Level (External trigger level time setting)	External trigger (CC1) is required

### 4.6 Serial Communication Settings

Serial communication is performed through the Camera Link Interface.

Table 4-6-1 shows serial communication settings.

**Table 4-6-1 Serial Communication Settings**

Parameter Items	Setup Value
Communication Speed (Baud rate)	9600bps/ 115200bps
Data Length	8-bit
Parity Bit	None
Stop bit	1-bit
Flow Control	None

### 4.7 Video Output Format

The camera outputs 8-bit digital data through 8 taps.

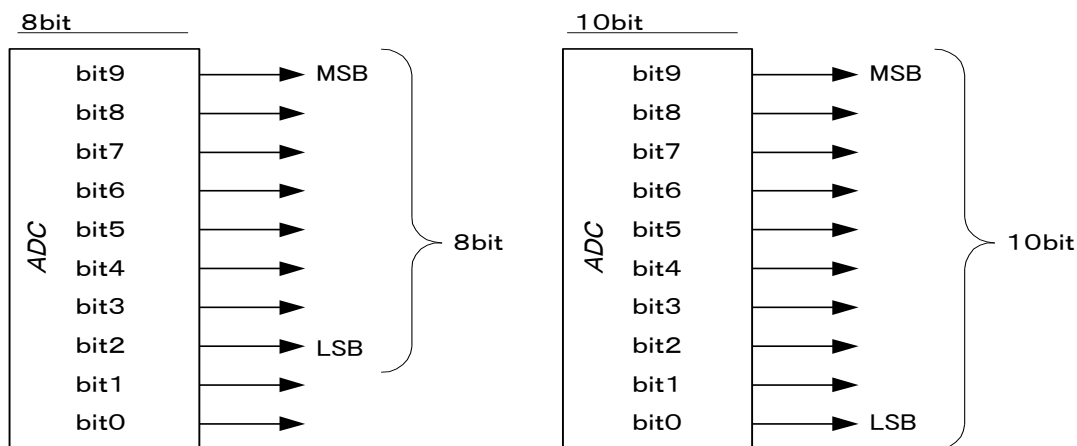

**Figure 4-7-1 Pin Assignments of Digital Data**



### GenICam\_2X2E

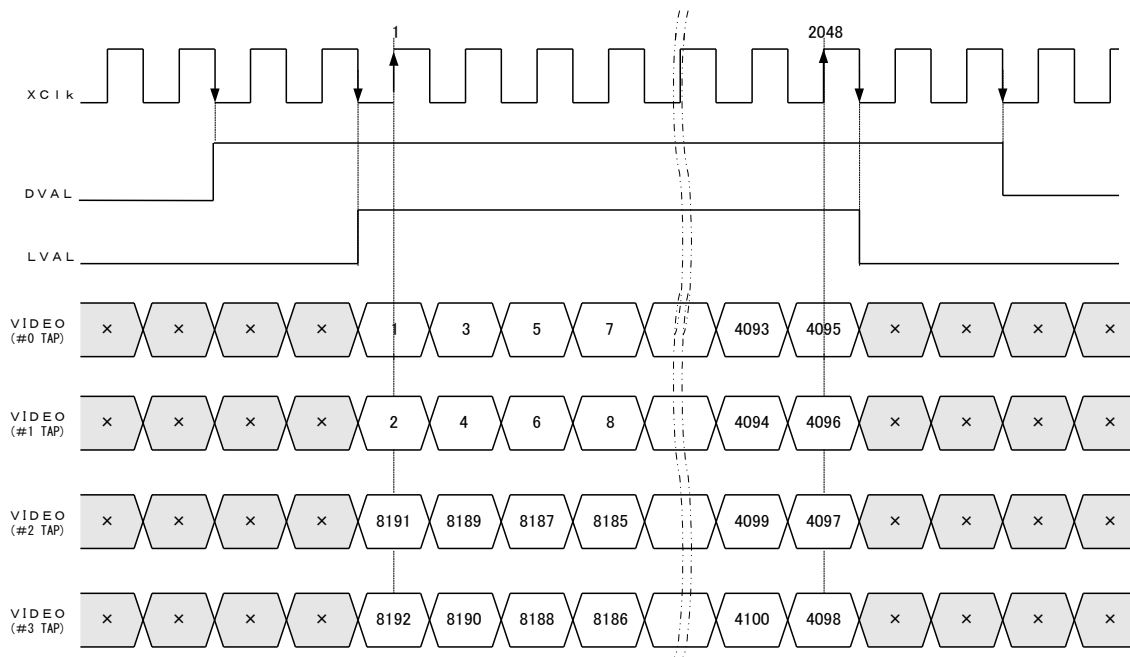

◆ FVAL = 0 (low level) fixed

Figure 4-7-2a Video Output Phase of the Camera

### GenICam\_1X2

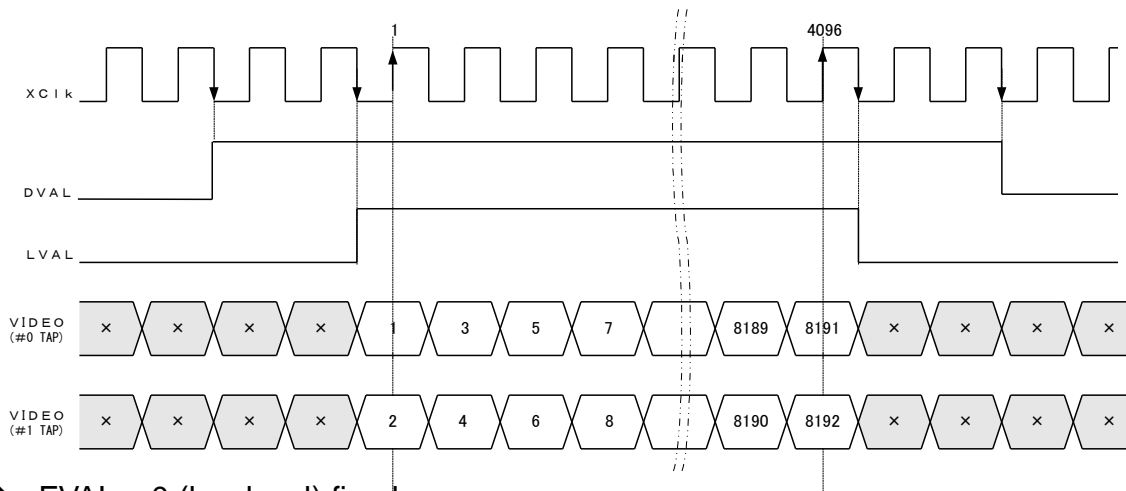

◆ FVAL = 0 (low level) fixed

Figure 4-7-2b Video Output Phase of the Camera

### 4.8 Exposure Mode and Timing Chart

The camera has three exposure modes. The overview of each mode and the timing are as follows.

#### 4.8.1 Free Run Exposure Mode (Programming time setting)

In free-run exposure mode, the exposure time (p) and the scan rate are determined by the settings made through serial communication.

The exposure and the readout repeat themselves in the scan period which is determined by the scan rate.

The range of programmable scan rate (reciprocal number of the scan period) and the timing chart of the exposure and the readout are shown below.

**Table 4-8-1-1 Programmable Exposure Time**

		Tap Geometry	85MHz	80MHz	60MHz	40MHz
p	Programmable exposure time (ns)	GenICam_2X2E	1000~3331000			
		GenICam_1X2				
1/scan	Scan rate(Hz)	GenICam_2X2E	300~ 39062	300~ 37037	300~ 27777	300~ 18382
		GenICam_1X2	300~ 20000	300~ 18518	300~ 13888	300~ 9416
r	Readout time(μs)	GenICam_2X2E	24.09	25.60	34.13	51.20
		GenICam_1X2	48.19	51.20	68.27	102.40

(unit:μs)

Notes:

\*The exposure time is increased by an increments of 200ns

\*Scan rate (1/scan) > Exposure time

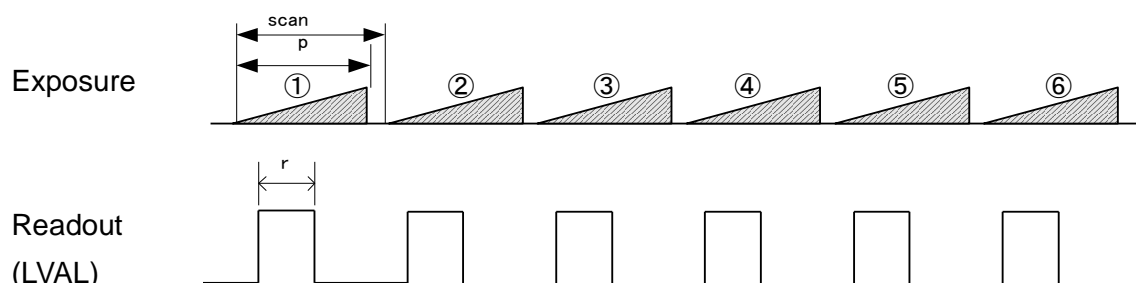

**Figure 4-8-1-1 Free Run Exposure Mode**

### 4.8.2 External Trigger Exposure Mode (Trigger Edge)

In external trigger exposure mode (Trigger Edge), the exposure time is determined by the setting for the line period parameter, each exposure starts with the rising edge and the line period is determined by the time from rising edge to rising edge of the internal control signal. The range of programmable exposure time, the timing chart of the exposure and the readout are shown below.

**Table 4-8-2-1 Programmable Exposure Time**

	Tap Geometry	85MHz	80MHz	60MHz	40MHz	
p	Programmable exposure time (ns)	1000~331000				
	GenlCam_2X2E					
r	Read out(μs)	24.09	25.60	36.00	51.20	
	GenlCam_1X2	48.19	51.20	72.00	102.40	
a	Trigger pulse Htime (μs)	≥0.024				
	GenlCam_1X2					
b	Trigger pulse Ltime (μs)	≥0.024				
	GenlCam_1X2					
c	Trigger pulse cycle (μs)	≥25.60	≥27.00	≥36.20	≥54.40	
	GenlCam_1X2	≥50.00	≥54.00	≥72.00	≥106.20	
d	CC1 Rising edge to LVAL Rising edge (μs)	≐ (p+15)				
	GenlCam_1X2					

\*\*The exposure time is increased by an increments of 200ns

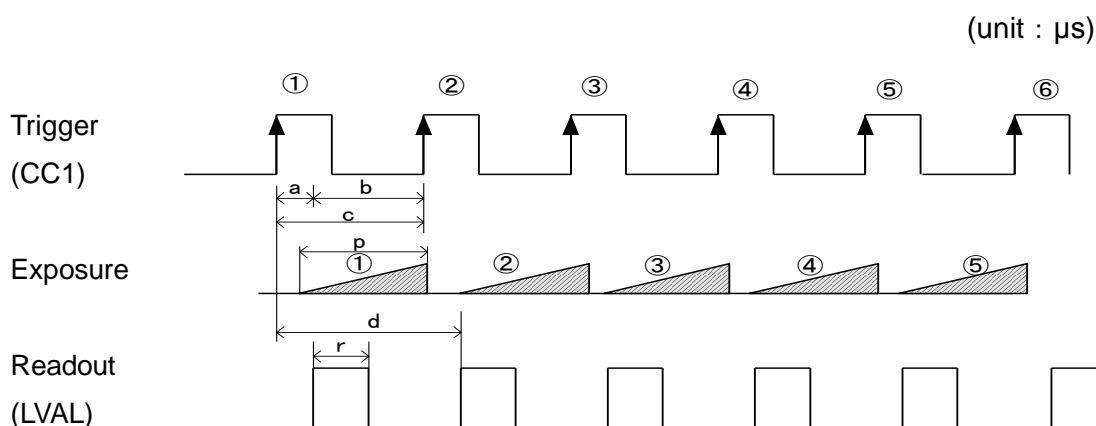

**Figure 4-8-2-1 External Trigger (Trigger Edge) Exposure Mode**

### 4.8.3 External Trigger Exposure Mode (Trigger Level)

In external trigger exposure mode (Trigger Level), the exposure time is determined by the setting for the line period parameter, each exposure starts with the rising edge and the line period is determined by high trigger pulse time. The range of programmable exposure time, the timing chart of the exposure and the readout are shown below.

**Table 4-8-3-1 Programmable Exposure Time**

		Tap Geometry	85MHz	80MHz	60MHz	40MHz
r	Readout time (μs)	GenlCam_2X2E	24.09	25.60	34.13	51.20
		GenlCam_1X2	48.19	51.20	68.27	102.40
a	Trigger pulse Htime (μs)	GenlCam_2X2E	≥23.40	≥24.80	≥34.00	≥52.20
		GenlCam_1X2	≥47.80	≥51.80	≥66.40	≥104.00
b	Trigger pulse Ltime (μs)	GenlCam_2X2E	≥2.200			
		GenlCam_1X2				
c	Trigger pulse cycle (μs)	GenlCam_2X2E	≥25.60	≥27.00	≥36.20	≥54.40
		GenlCam_1X2	≥50.00	≥54.00	≥72.00	≥106.20
d	CC1 Falling edge To LVAL Rising edge (μs)	GenlCam_2X2E	≐14			
		GenlCam_1X2				

**Table 4-8-3-1 Programmable Exposure Time**

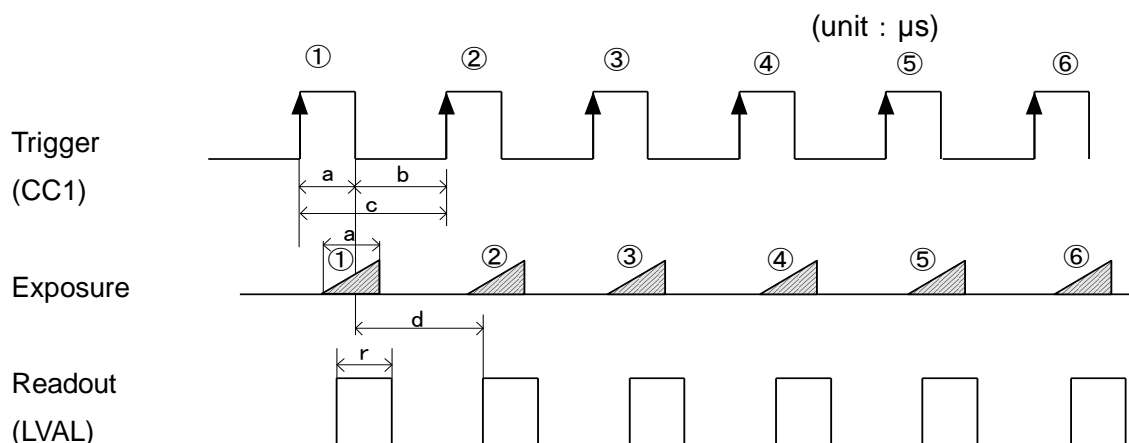
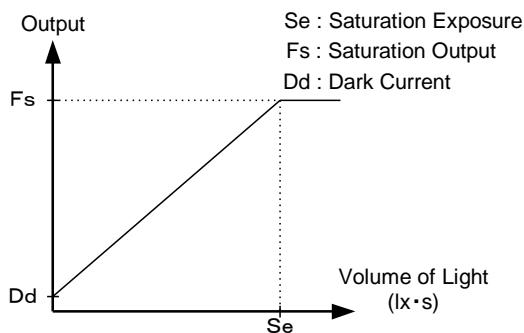

**Figure 4-8-3-1 External Trigger (Trigger Level) Exposure Mode**

### 4.9 Setting Offset

In the diagram below, the horizontal axis indicates the volume of light and vertical axis indicates the output.

F<sub>s</sub> shows the output at saturation. D<sub>d</sub> shows the output at darkness. (Both F<sub>s</sub> and D<sub>d</sub> are digital.) S<sub>e</sub> shows for the saturation current, or the amount of exposure when the output saturates.



**Figure 4-9-1 Saturation Exposure and Dark Current Output**

By setting the offset, you can set the Y-intercept arbitrarily. DF shows the digital offset value. The gradients of lines do not change.

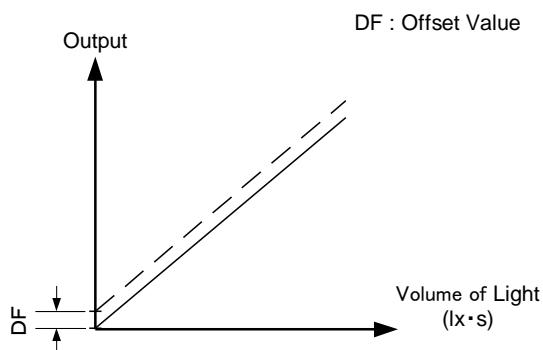

**Figure 4-9-2 Offset Adjustment**

- ◆ Adjust gain and offset to meet your system’s requirements.

## 4.10 Setting Gain

The camera can adjust the analog gain (x1 to X10.0 in 8 steps) and the digital gain. As the diagram below indicates, increasing the gain setting increases the slope of the camera's response curve and results in a higher camera output for a given amount of light.

Analog gain can be changed by sending the "gax" command.

Digital gain can be changed by sending the "gdx" command.

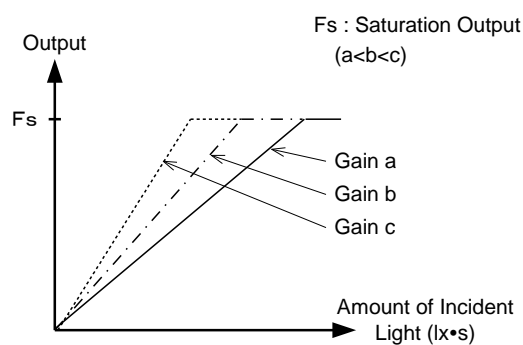

**Figure 4-10-1 PGA Gain Adjustment**

- ◆ Gain and noise values are proportionally related.
- ◆ Adjust amount of gain in accordance with the requirements of your camera system.

Gain-Sensitivity is shown below.

**Table 4-10-1 Gain-Sensitivity**

	Analog Amplifier		Sensitivity (V/lx□s)
0	x1.00	0.0dB	50
1	x2.00	6.0dB	100
2	x3.00	9.5dB	150
3	x4.00	12.0dB	200
4	x5.00	14.0dB	250
5	x6.00	15.6dB	300
6	x8.00	18.1dB	400
7	x10.00	20.0dB	500

Digital gain x1, Pixel correction: default, (Factory white correction data, Correction level 800DN)

### 4.11 Pixel Correction

Generally speaking, image sensors (CCD, CMOS and so on) have fixed pattern noise and photo response non-uniformity. Lens shadings and light sources also can cause non-uniformity. The camera is set to the optimal correction before shipping in order to provide images of high grade.

The camera also has the function of user white correction to cope with lens shading and non-uniform illumination.

Cal\_bl :Output data of each pixel at perfectly dark (digital)  
 Cal\_wh :Output data of each pixel in uniform illumination (digital)  
 Target-val :Target value for correction (10-bit digital)  
 Vin :Input data (digital)                      Vout :Output data (digital)  
 The corrected data is expressed in the following equation.  

$$Vout = (Vin - Cal\_bl) \times Target\_val / (Cal\_wh - Cal\_bl)$$

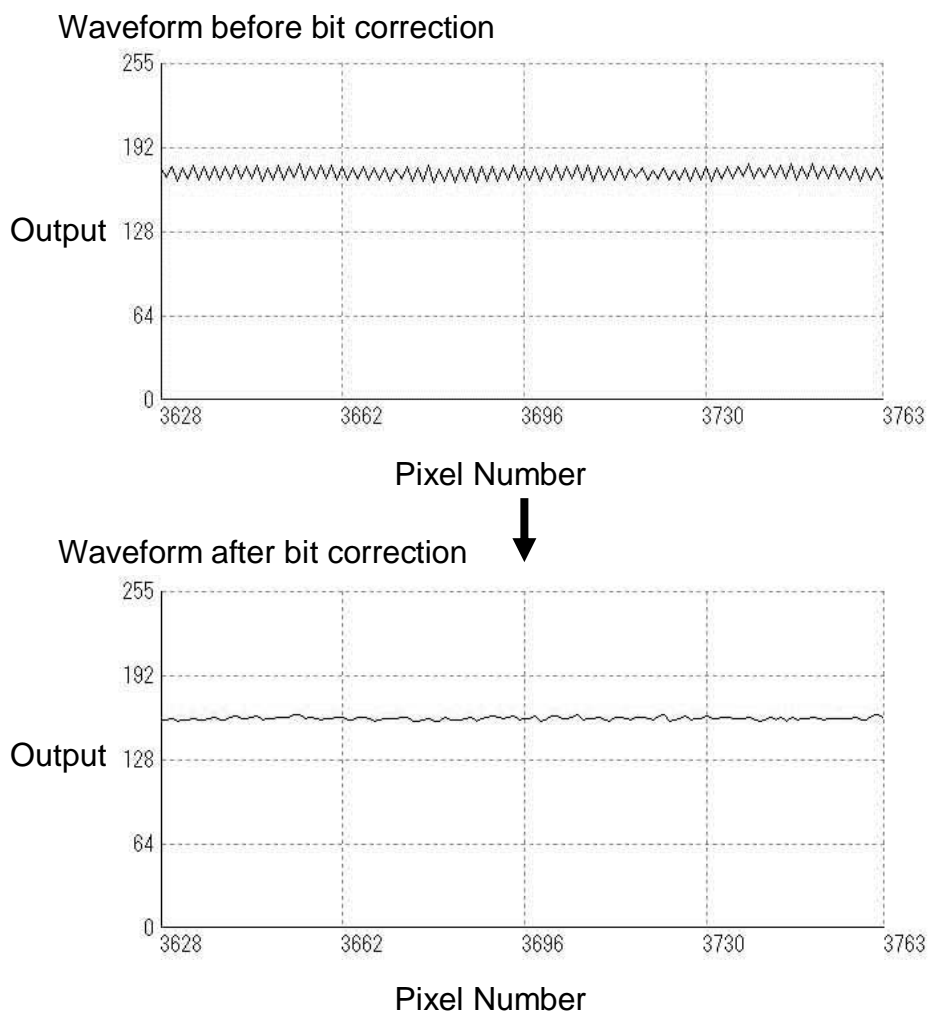

Figure 4-11-1 Waveform before and after bit correction



### 4.11.1 Command Settings

Set the correction on or off, acquire user white correction data by sending commands through serial communication.

Examples of command settings:

The example of command settings

ffcm 0: No correction

ffcm 1: factory black correction + factory white correction (factory setting)

ffcm 2: factory black correction + any white correction

ffcm 3: unused

ffcm 4: any black correction + factory white correction

ffcm 5: any black correction + any white correction

blk: any black correction data acquisition

wht: any white correction data acquisition

### 4.11.2 How to calibrate the camera

- (1) Remove the lens cap and place a white object. Then you can acquire user white correction data. With a lens, the shading by both the lens and the light source will be simultaneously corrected. At this time, please defocus a little to avoid being affected by the non-uniformity of the object.
- (2) Send the "wht CR" command through serial communication.
- (3) Confirm that the camera returns ">OK" and ">wht". Thus user white correction data is saved and loaded to the camera.
- (4) Send the "ffcm 2 VAL CR" command through serial communication. Then the user white correction will be on and set the correction level as "VAL".

## 4.12 Test Pattern

This camera can generate a test pattern. Use the test pattern to verify the proper timing and connections between the camera and the frame grabber board.

The test pattern of the camera is below.

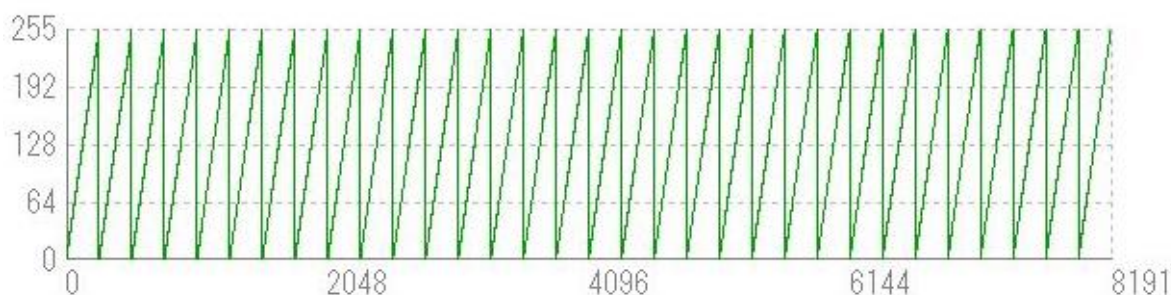

**Figure 4-12-1 Test Pattern of the Camera**



**Figure 4-12-2 Test Image the Camera**

The test pattern is a ramp from 0 to 255DN in 8-bit mode, and then it repeats itself from 0 again 32 times.

The test pattern is a ramp from 0 to 1023DN in 10-bit mode, and then it repeats itself from 0 again 8 times.

## 5 Confirming Camera Settings

### 5.1 Before Power-on

(1) Confirm the pin assignment of the power cable.

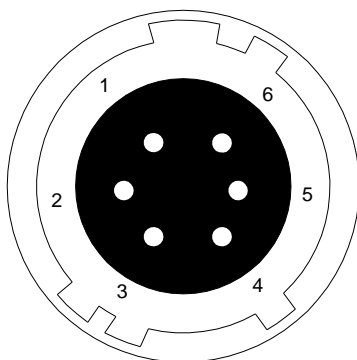

No	NAME	Colour of Cable
1	12 -15V	White
2	12 -15V	Red
3	12 -15V	-
4	GND	Green
5	GND	Black
6	GND	-

**Figure 5-1-1 Pin Assignment of Power Cable**

The cable colours of the standard cable DGPSH-10 are shown as above.

- (2) Confirm the direction and the channel of the cables. Some Camera Link cables are directional.
- ◆ If one of the connectors says “Camera side”, connect it to the camera.

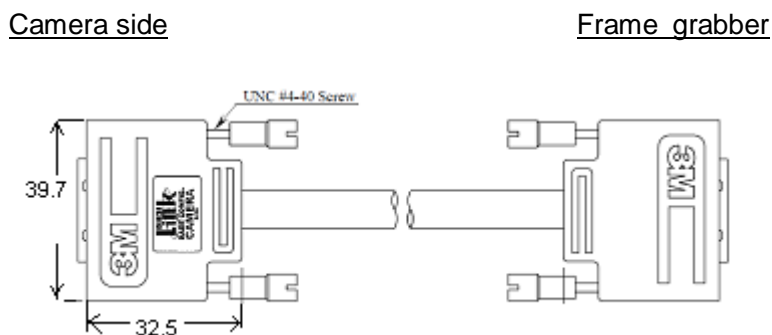

Figure 5-1-2 Connection Direction of Camera Cable

The connection channel of in case of “Solios”

CL1 = CHANNEL #0

CL2 = CHANNEL #1

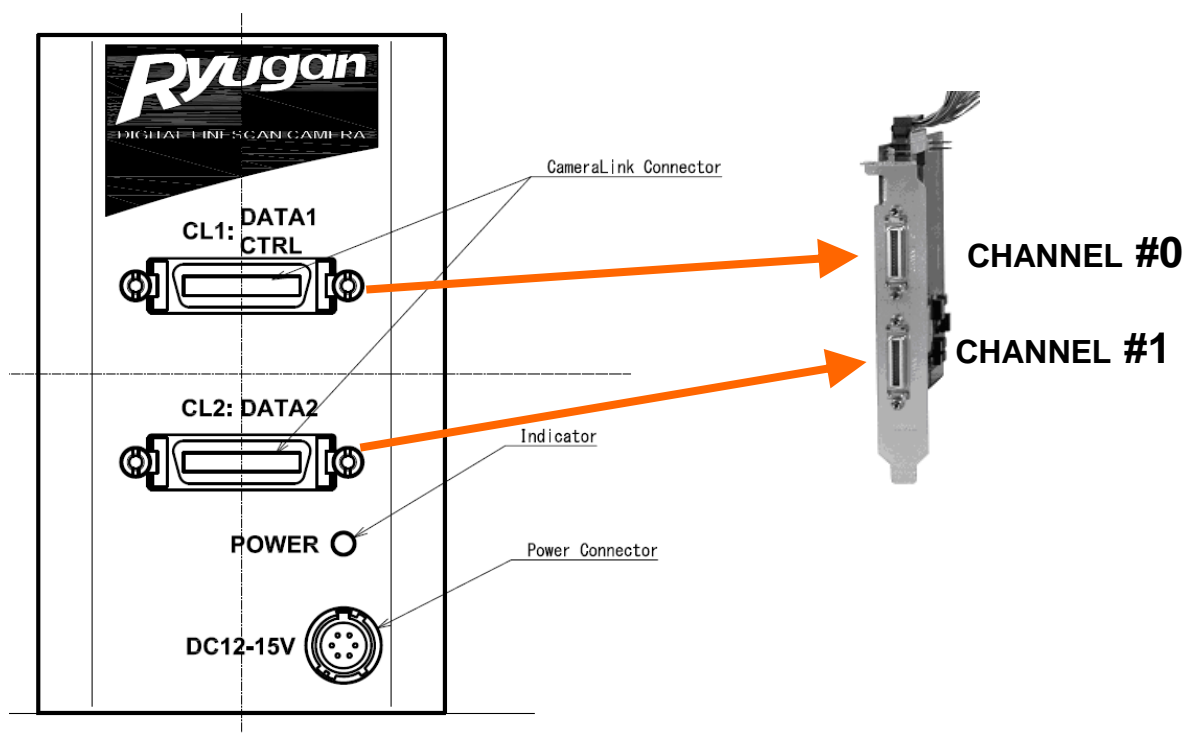

Figure 5-1-3 Channel of Camera Link Cables

### 5.2 After Powemr-on

- (1) Confirm sent and received commands using the camera control utility. Launch NCamCtrl, set COM port and connect. Click “Memory Dump” and wait for the response.

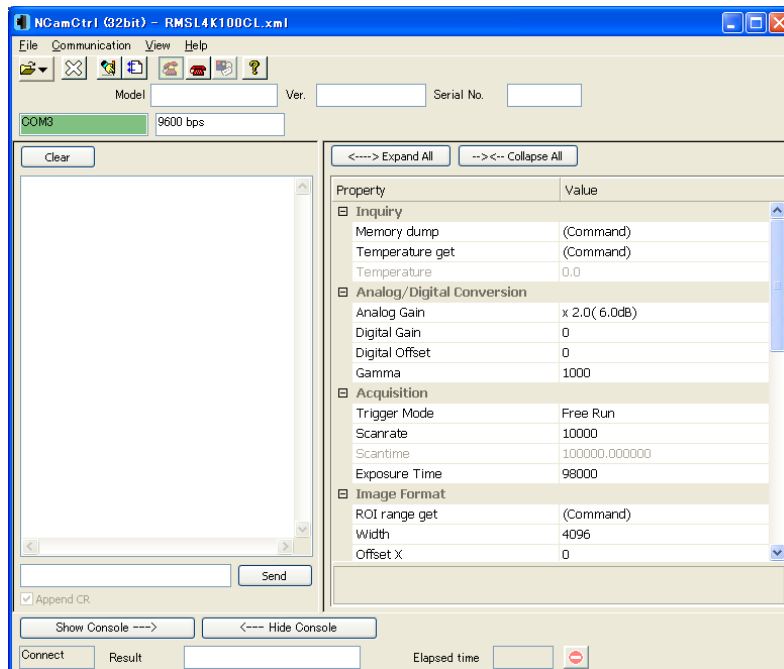

Figure 5-2-1 Confirmation of Connection

- (2) Set a trigger mode and a video output mode with the camera control utility.

Example: Trigger mode = Free run  
 Video output mode =8-bit

Property	Value
<b>Acquisition</b>	
Trigger Mode	Free Run
Scanrate	10000
Scantime	100000.000000
Exposure Time	98000
<b>Image Format</b>	
ROI range get	(Command)
Width	4096
Offset X	0
Binning horizontal mode	Sum
Binning horizontal	1
Reverse X	<input type="checkbox"/>
Reverse X control	by Command
Pixel format	Mono8
Test pattern	Off
<b>Output</b>	
Pixel clock	80 MHz
Tap geometry	GenICam_1x8

Figure 5-2-2 Setting of Exposure Mode and Video Output Mode

- ◆ If you have your own application to check the images, select suitable settings.

(3) Capture images using a camera interface board utility. In case of Matrox's Solios, it is convenient to use Intellicam.

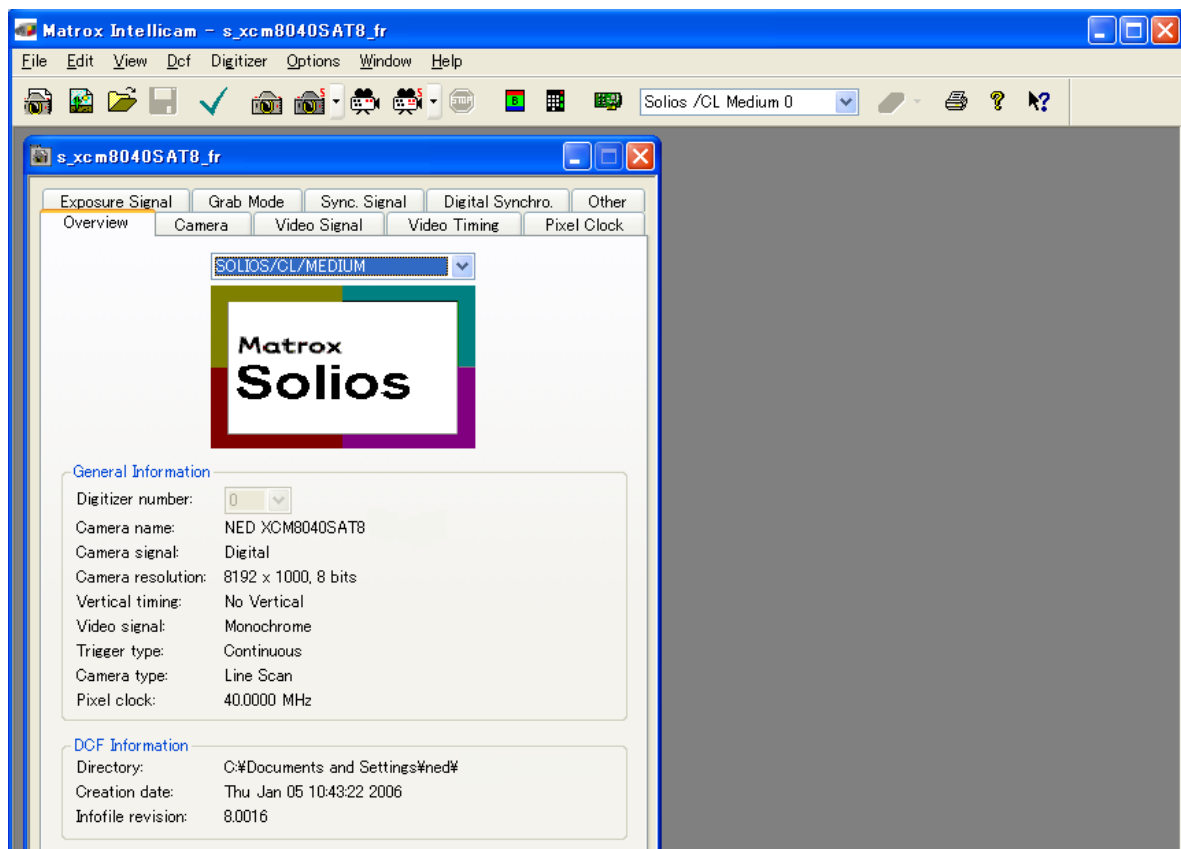

Figure 5-2-3 Solios Window

### 5.3 In Operation

(1) Does acquisition time out error occur?

<Cause>

<1> Captured images are too heavy.

If there are many filtering processes, the assignments to the driver may be insufficient.

<2> The cables are detached from the connector

Ensure that the power cable and Camera Link cables are connected to the camera correctly.

<3> Camera Link cables come under the influence of noise when the cables are laid near a light source inverter line or a power line. The personal computer in use may be reset.

(2) Are there dark lines in the direction of vertical scanning on the image?

<Cause>

<1> Dust on the sensor window

Dust may come on the sensor window from the inside or the outside of the camera. Remove the dust with air or a lens cleaner.

## 6 Sensor Handling Instructions

### 6.1 Electrostatic Discharge and the Sensor

CMOS sensors are susceptible to damage from electrostatic discharge and can become defective.

### 6.2 Protecting Against Dust, Oil and Scratches

The CMOS sensor window is part of the optical path and should be handled like other optical components with care. If you use the camera in a dusty area, prepare a dust-proof enclosure. Dust can obscure pixels, producing dark lines on the image.

### 6.3 Cleaning the Sensor Window

Dust: Can usually be removed by blowing the window surface using a compressed air blower.

Oil: Wipe the window with a lint-free cloth wiper moistened with ethyl alcohol carefully and slowly.



## 7 Troubleshooting

The following pages contain several troubleshooting charts that can help you find the cause of problems user sometimes encounter.

### 7.1 When there is no Image

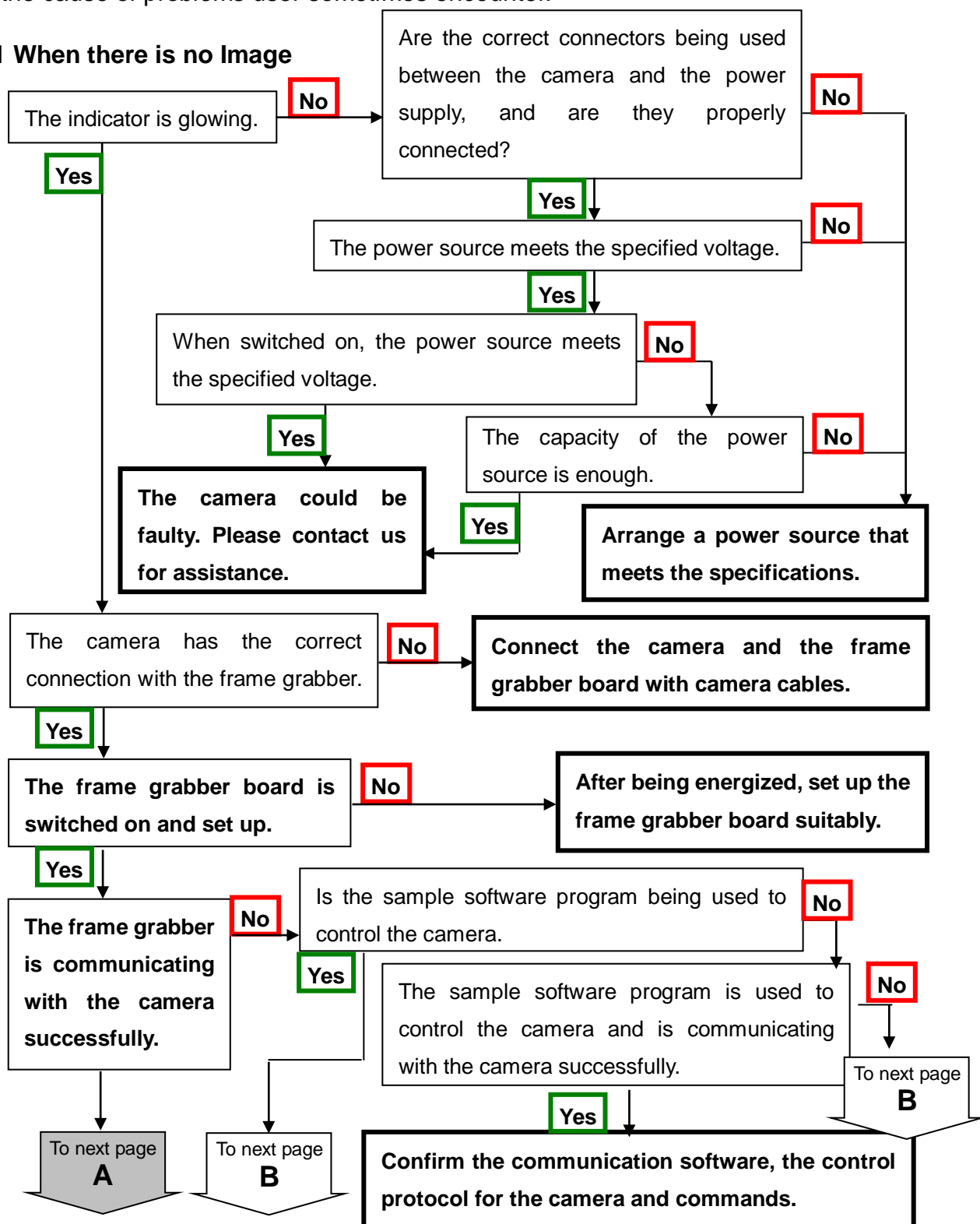

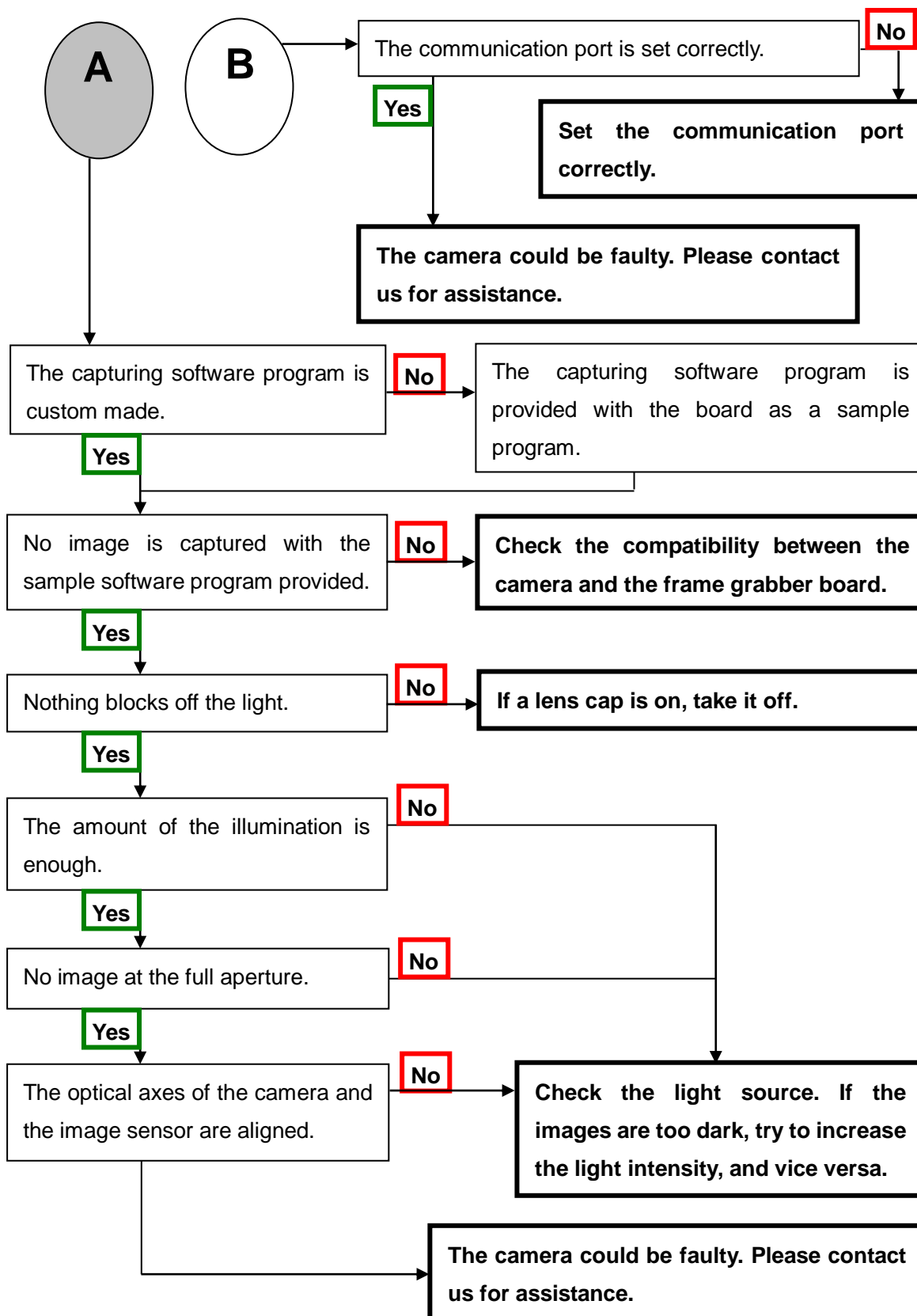

### 7.2 When Noise is present in the Image

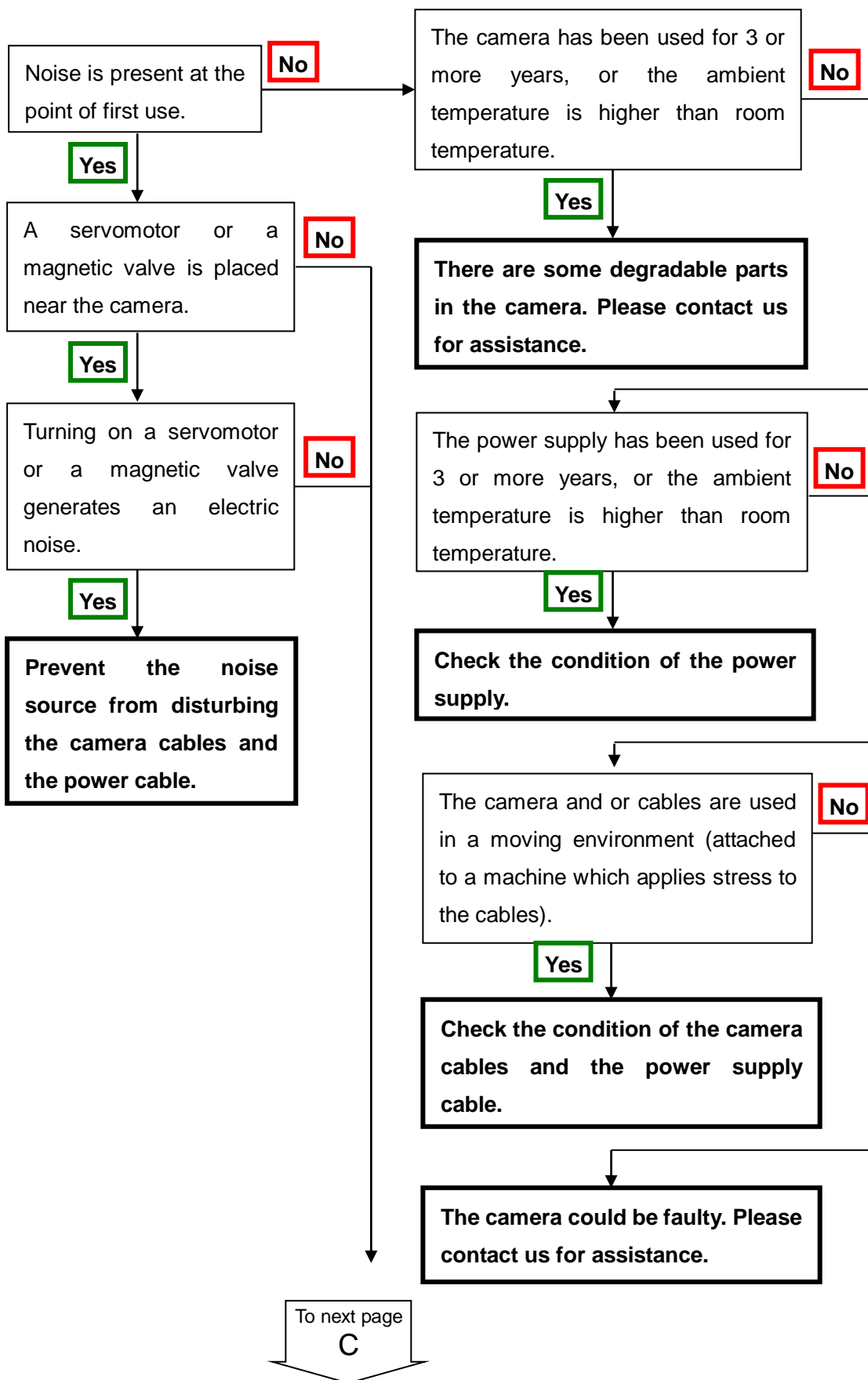

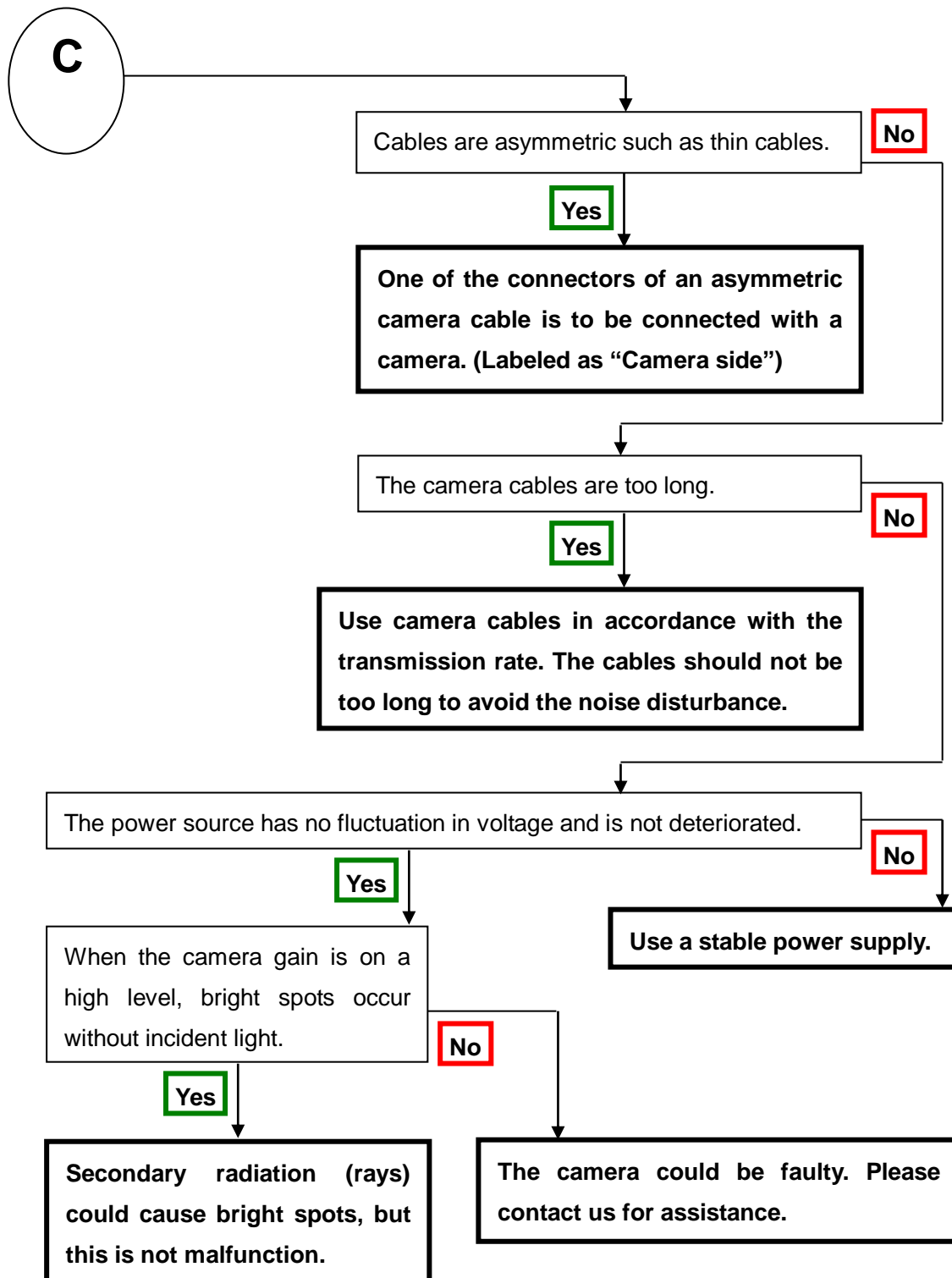

### 7.3 When the Camera becomes hot

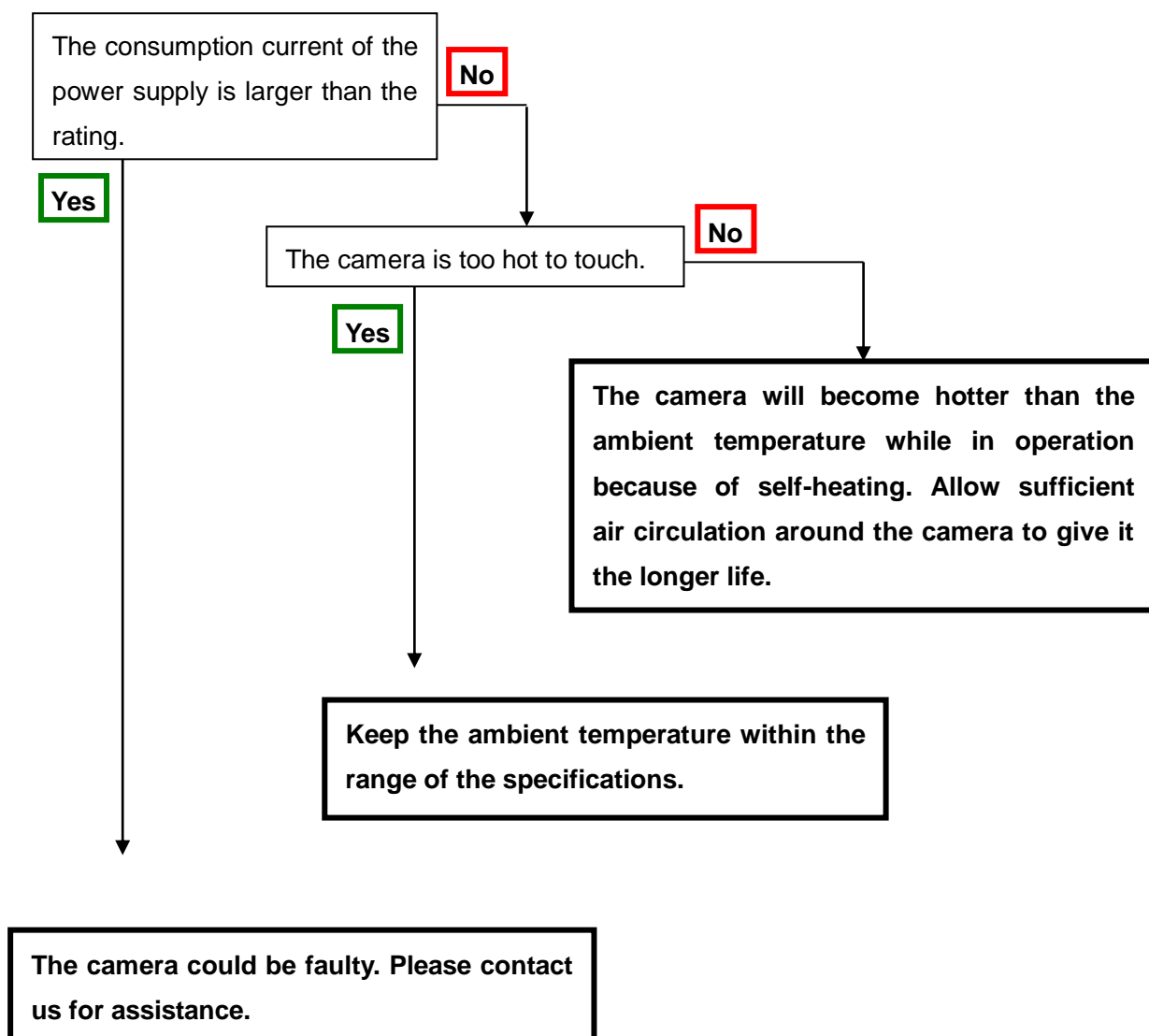

## 8 Others

### 8.1 Notice

- No part of this document may be reproduced in any form, in whole or in part, without the expressed written consent of NED.
- Contents of this document are subject to change without prior notice.
- Every care has been taken in the preparation of this User's Manual. If you should discover any errors or omissions, please notify your nearest NED representative.

### 8.2 Contact for support

Nippon Electro-Sensory Devices Corporation

#### Head Office

2-5-12, Itachibori, Nishi-ku, Osaka 550-0012, Japan

Phone +81-6-6534-5300

Fax +81-6-6534-6080

#### Tokyo Branch

Jiburaruta Seimei Oi BLDG., Room No.402

1-45-2, Oi, Shinagawa-ku, Tokyo 140-0014, Japan

Phone +81-3-5718-3181

Fax +81-3-5718-0331

#### Nishi-Nippon Branch

Twin Square 1-8-28 Enokida, Hakata-ku, Fukuoka, 812-0004, Japan

Phone +81-92-451-9333

Fax +81-92-451-9335

#### URL

<http://ned-sensor.co.jp/>

#### E-Mail

[sales@ned-sensor.com](mailto:sales@ned-sensor.com)

## 8.3 Product Support

### 8.3.1 Warranty card (attach a separate)

Read carefully the Warranty card, please treasure it.

### 8.3.2 When you need to repair

If there is still a problem with your camera after checking it in accordance with the troubleshooting guide, turn off the power and call your NED representative.

In such case, please inform us of the status of the camera. You can get the status by executing the “sta” command,

The example of the camera status.

```
sta CR
>OK
>Type=RMSL8K39CL
>Ver.=1.22_0x0106
>Serial=21704
>gax 0
>gdx 0
>odx 0
>inm 0
>prd 8183
>expo 120000
>ffcm 1
>ffct 800
>tpn 0
>rev 0
>pxf 0
>clkcl 85
>tapg 0
>gamma 1000
>logmode 1
>sta
```

## Revision History

Revision Number	Date	Changes
01	June 11, 2018	Initial release