

MERCURY2 PRO SERIES

ME2P-2622-4GM-P NIR



- High definition, high quality image
- 1.1" global shutter CMOS sensor
- 26.21 Megapixels
- Compatible with GenICam™ and GigE Vision®
- Multiple functions
- Power over Ethernet (PoE)
- 2 programmable GPIOs

The MERCURY2 PRO PoE series (ME2P-G-P) camera is DAHENG IMAGING's high definition industrial digital camera, featuring outstanding performance, compact design and flexible installation.

ME2P-2622-4GM-P NIR is a NIR enhanced GigE Vision camera with the Grade2 Gpixel GMAX0505 CMOS sensor, and the sensor has optimized response in the near-infrared band. The ME2P-2622-4GM-P NIR camera has opto-isolated I/Os that adapt to specific needs. Four-side mounting holes provide maximum installation flexibility for ME2P-G-P. Thanks to the extremely compact design (36mm × 31mm × 50.6mm), locking screw connectors, the MERCURY2 PRO PoE series cameras can secure the reliability of cameras deployed in harsh environments.

Featuring compact design, outstanding performance, ease of installation and use, the MERCURY2 PRO cameras are especially suitable for machine vision applications such as industrial inspection, medical, scientific research, education, security and so on.

Features

- Power over Ethernet (IEEE802.3af compliant)
- Programmable ROI, increased frame rate with partial scan
- Gain and exposure and programmable
- Support auto gain and auto exposure
- Four acquisition controls: Single frame acquisition/Continuous acquisition/Software trigger acquisition/External trigger acquisition
- Trigger mode: Frame Start /Frame Burst Start
- Support Timer, Counter, LUTs and Parameter Set
- Support Gamma, Sharpness, Black Level, Static Defect Pixel Correction and Flat Field Correction
- Support Noise Reduction, Binning, Decimation, Digital Shift and Reverse X/Y(horizontal and vertical mirroring)
- Adjustable packet-size and packet-delay, and reserved bandwidth
- Support Remove Parameter Limit to expand the range of exposure, gain, and so on
- 16KB data storage area for saving algorithm coefficients and parameter configuration
- Compatible with GenICam™ and GigE Vision®, can be used in a wide range of 3rd-party software such as HALCON, MERLIC and LabVIEW directly
- Optimized software package for 32/64bit Windows, and support Linux, ARMv7, ARMv8 and Mac OS
- Multiple samples and easy-to-integrate SDKs for various programming tools
- Regulations: CE, RoHS, GenICam, GigE Vision, IEEE802.3af (PoE)

Performance Specifications

Model	ME2P-2622-4GM-P NIR
Interface	GigE
Resolution	5120(H) × 5120(V)
Frame rate	4.5 fps
Sensor	1.1", Gpixel GMAX0505 Global Shutter CMOS
Pixel size	2.5 μm × 2.5 μm
Pixel Bit Depth	8bit, 12bit
Spectrum	Monochrome / NIR
Exposure time	14μs~1s

Mechanical Specifications

Weight	75g
Dimensions	36(W)x31(H)x50.6(L) mm, w/o connectors

Technical Drawing

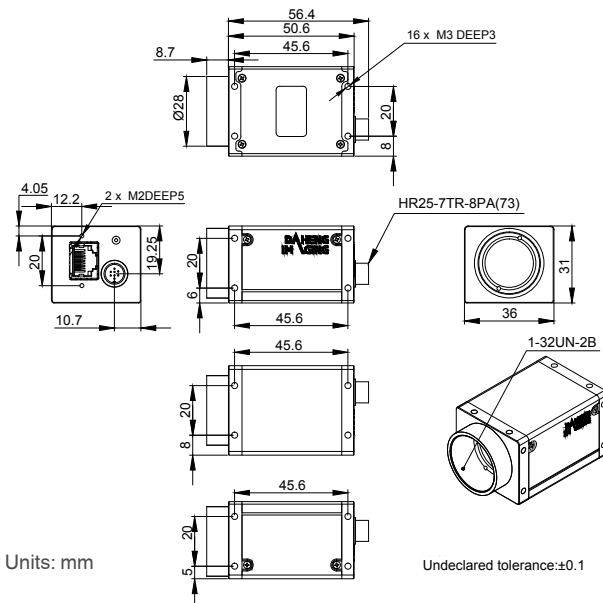

Electrical Specifications

Power requirement	12~24 VDC via 8-Pin or PoE
I/Os	1 input / 1 output, 2 GPIOs
Data interface	RJ45 with locked
Power consumption	<4.25W @24VDC; <4.75W @PoE

Environmental Specifications

Operating temp.	0°C ~ +45°C
Storage temp.	-20°C ~ +70°C
Operating humidity	10% ~ 80%

Optical Specifications

Lens mount	C-Mount (standard), CS-Mount (optional)
------------	---

Spectral Response

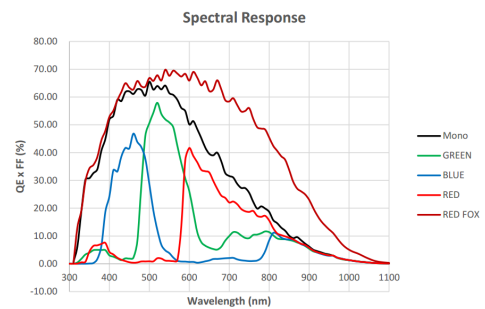

ME2P-2622-4GM-P NIR

China Daheng Group, Inc. Beijing Image Vision Technology Branch

12F Daheng Science & Technology Tower, No.3 Suzhou Street, Haidian District,

Beijing China, 100080

Tel: +86 10 82828878

E-mail: isales@daheng-imaging.com

For more information please visit : www.daheng-imaging.com/en

Specifications are subject to change without prior notice.

Copyright © 2022 China Daheng Group, Inc. Beijing Image Vision Technology Branch. All rights reserved.

March 07, 2022