

# Dhyana 400BSI V2.0

## BSI Scientific CMOS Camera

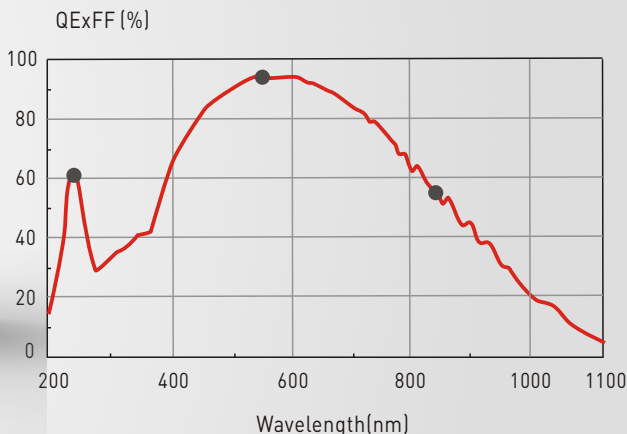

**74** fps  
CameraLink

**40** fps  
USB3.0

Faster Capture

**6.5**  $\mu\text{m}$   
Pixel Size

**4.2** MP  
Resolution

High Resolution

**0.2**  $e^-$   
DSNU

**0.3** %  
PRNU

**1.2**  $e^-$   
Read Noise

More Accurate

**60** % QE UV light  
@ 254 nm

**95** % QE Visible light  
@ 550 nm

**53** % QE Near-infrared  
@ 850 nm

High Sensitivity

# A New Breakthrough for New Discoveries!

---

Since its launch, the Dhyana 400BSI sCMOS camera has been receiving great attention and focus. The image quality of the product is fully recognized to be comparable, or even better than its competitors. However, the Tucsen R&D group continues to pursue greater levels of excellence. This resulted in an upgraded product, the Dhyana 400BSI [V2.0].

The Dhyana 400BSI [V2.0] achieves a core breakthrough in the transmission speed compared with 400BSI [V1.0], and a high-speed data transmission rate of 74fps @ Cameralink and 40fps @ USB3.0 at full resolution. Moreover to meet the demands for accurate quantification for high-end scientific imaging such as single molecule and super resolution, the 400BSI [V2.0] calibrated DSNU & PRNU, minimized the difference between each pixel and reduced fixed pattern noise. So we are now able to achieve more accurate quantitative imaging data, providing a guarantee of reliable analysis results. The DSNU & PRNU calibration is of a great importance of quantitative analysis.

Simultaneously, the Dhyana 400BSI [V2.0] preserves all the essences of Dhyana 400BSI [V1.0], including the latest developed back-illuminated sCMOS sensor, ultra-high quantum efficiency of 95%, microscope-friendly  $6.5\mu\text{m} \times 6.5\mu\text{m}$  pixel and  $1.2\text{e-}$  @ Median ultra-low readout noise.

So, no matter of chasing for brilliant scientific images or accurate images quantitative data, 400BSI [V2.0] is easy to implement!

## DSNU/PRNU calibration, more accurate quantitative analysis

To improve the overall performance of the camera, the Dhyana 400BSI (V2.0) was calibrated in DSNU (dark signal non-uniformity) and PRNU (photo response non-uniformity) characteristically. After calibration, the DSNU value reduced from 0.3e- to 0.2e-, the PRNU value reduced from 1.6% to 0.3%. Thus the new upgraded camera has a more sophisticated capabilities, making it more suitable for quantitative analysis applications.

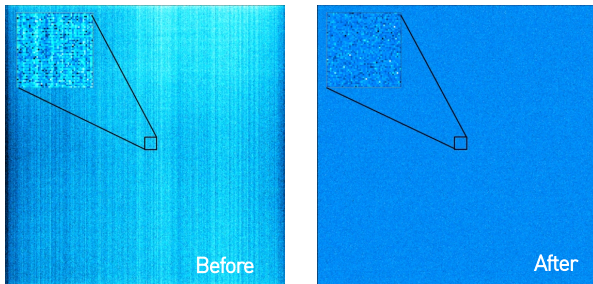

Dark Signal Non-Uniformity (DSNU) Optimization

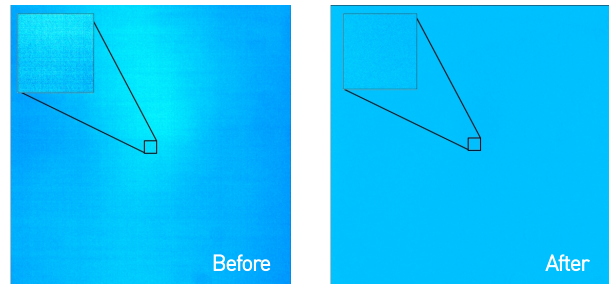

Photo Response Non-Uniformity (PRNU) Optimization

## Top-level cooling technology to reduce the impact of noise

Dhyana 400BSI V2.0 advanced cooling mode can further reduce the impact of noise on imaging: compared to 1.2e- readout noise and 0.2e-DSNU, the dark current corresponding to 100ms is less than 0.02e-. In high-end imaging applications, dark current becomes negligible.

Cooling Method	Cooling Temperature	Dark Current
Forced air (Ambient at +20 °C)	-15°C	0.15e-/p/s(typ.)
Water (Ambient at +20 °C)	-25°C	0.10e-/p/s(typ.)

## Wide spectral response range, high sensitivity

With its ultra-low noise, the advantage of the quantum efficiency in Dhyana 400BSI (V2.0) is very significant. This is a huge breakthrough for scientific applications, not only in the visible region, but also in the ultraviolet and near-infrared.

Quantum Efficiency Comparison ►

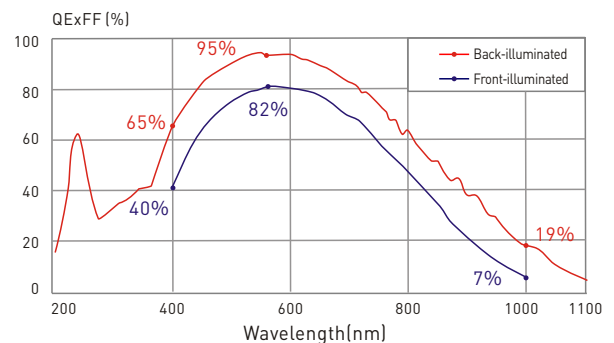

# 74fps @ CameraLink, 40fps @ USB3.0, faster data capture

In addition to the signal to noise ratio advantage, the Dhyana 400BSI (V2.0) has enhanced transmission speed, on one hand through the new CameraLink interface to meet the needs of high-end imaging research for higher frame rates, on the other hand through hardware improvements that increase the USB 3.0 throughput. These have achieved the ultimate transfer rate of 74fps with CameraLink and 40fps with USB3.0 at 4.2 MP full resolution.

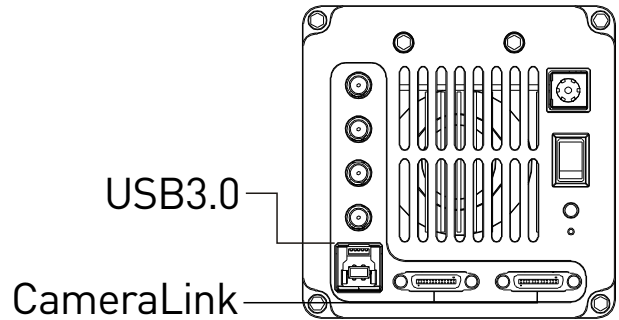

Column	Row	USB3.0	CameraLink
2048	2048	40.4fps	74.0fps
2048	1024	79.9fps	147.9fps
2048	512	158.8fps	293.9fps
2048	256	317.6fps	582.8fps
2048	128	629.2fps	1147.9fps
2048	64	1242.6fps	2227.8fps

## Third-party applications

Third-party applications supported by Dhyana 400BSI (V2.0) have also been greatly expanded, including Micromanager, Labview, Matlab, etc., to provide more application support and help.

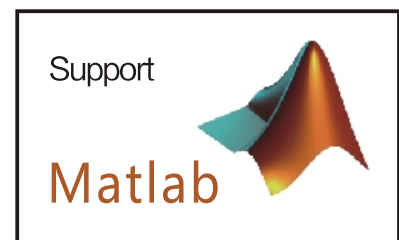
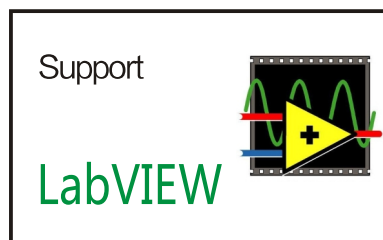

# Customer applications

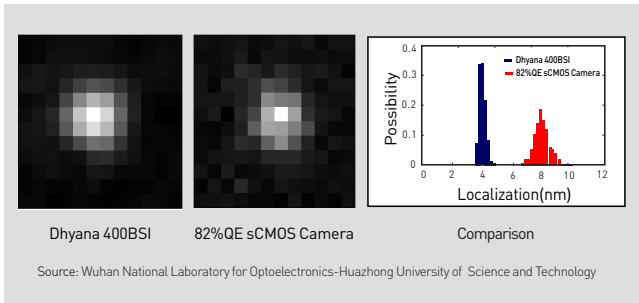

## Single molecule localization

The high SNR can effectively improve the intensity of single-molecule fluorescence emission. The statistical results of the localization accuracy of the fluorescent sphere shows that the accuracy of localization with 400BSI is twice as that of the third generation 82% QE sCMOS camera.

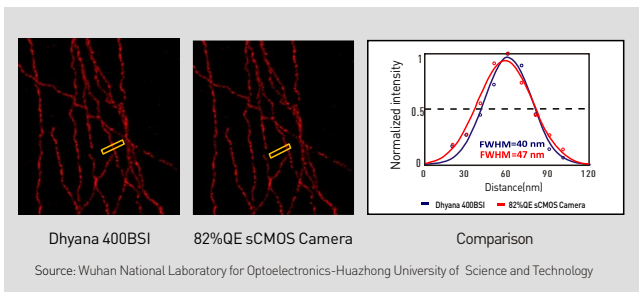

## Super-resolution imaging

The lower the FWHM, the higher the resolution. In STORM super-resolution imaging, the capturing spatial resolution of 400BSI reaches to 40 nm, while those of the third generation of 82% QE sCMOS can only achieve 47 nm resolution, so the spatial resolution of 400BSI with STORM super resolution microscope carries a superiority of 7nm.

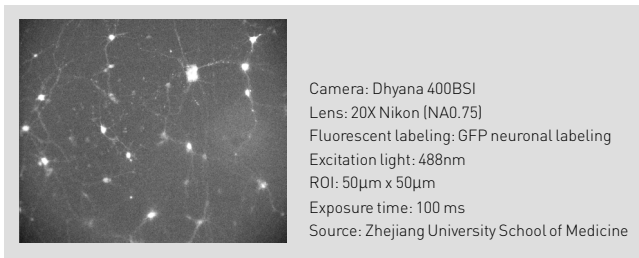

## Neuron fluorescence imaging

With the increasing of the exposure time, luminescent fluorophores produce phototoxicity to the cells. Compared with other cameras, the exposure time of 400BSI is shorter, which can protect cell samples from light damage better.

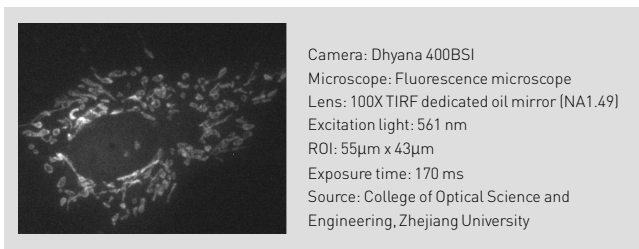

## TIRF wide field imaging

In the TIRF applications, the light signal of the samples is very weak, but 400BSI with the ultra-high SNR camera is able to capture the practical and good quality of images effectively with rather short exposure time, resulting in a faster and fully widefield imaging.

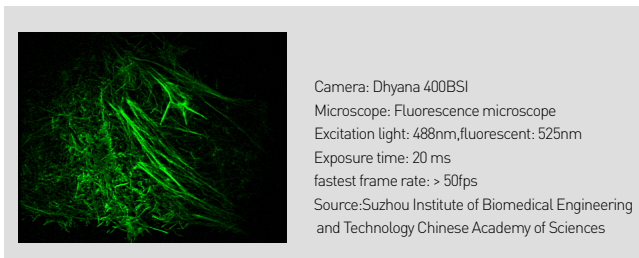

## SIM cytoskeleton imaging

SIM imaging requires the cameras to capture as sharp as possible pictures with as low as possible the exposure time, along with others same shooting conditions, the Dhyana 400BSI [V2.0] has a significant signal-to-noise ratio advantage, resulting in better images quality than other cameras.

# Technical Specifications

Model	Dhyana 400BSI (V2.0)
Sensor size	1.2"
Sensor model	Backside-illuminated sCMOS
Color/Monochrome	Monochrome
Quantum efficiency	60%@254nm, 95%@550nm, 53%@850nm
Effective resolution	2048(H) x 2048(V)
Pixel size	6.5μm x 6.5μm
Effective area	13.3mm x 13.3mm
Full well capacity	45,000e <sup>-</sup>
Frame rate	74fps @4.2MP @CameraLink 40fps @4.2MP @USB3.0
Readout noise	1.2e <sup>-</sup> (Median); 1.3e <sup>-</sup> (RMS)
Shutter type	Rolling Shutter / Global Reset
Exposure time	6.6μs-10s
DSNU	0.2e <sup>-</sup>
PRNU	0.3%
Cooling	Forced air (Ambient at +20°C): -15°C Water (Ambient at +20°C): -25°C
Dark current	Forced air: 0.15 e <sup>-</sup> /p/s [-15°C](typ.) Water: 0.10 e <sup>-</sup> /p/s [-25°C](typ.)
Binning	2x2 / 4x4
Sub-array	Available
External trigger mode	Standard / Synchronous / Global trigger
Trigger delay function	0-10s(1μs steps)
External trigger connector	SMA
Signal output ports	3 { Exposure / Global / Readout }
Digital interface	USB3.0 / CameraLink
SDK	Support
Bit depth	16bit
Lens mount	C-mount
Power supply	12V / 8A
Power consumption	55W
Camera size	85mm x 85mm x 125mm
PC software	Mosaic / LabVIEW / Matlab / Micromanager MetaMorph
Compatible system	Windows / Linux
Operating environment	Temperature: 0-40°C Humidity: 10%-85%

# Applications

- Super-resolution microscopy
- Real-time confocal microscopy
- Gene sequencing
- Live-cell imaging
- Single molecule detection
- Astronomy observation
- FRET
- TIRF
- DIC

# Dimensions

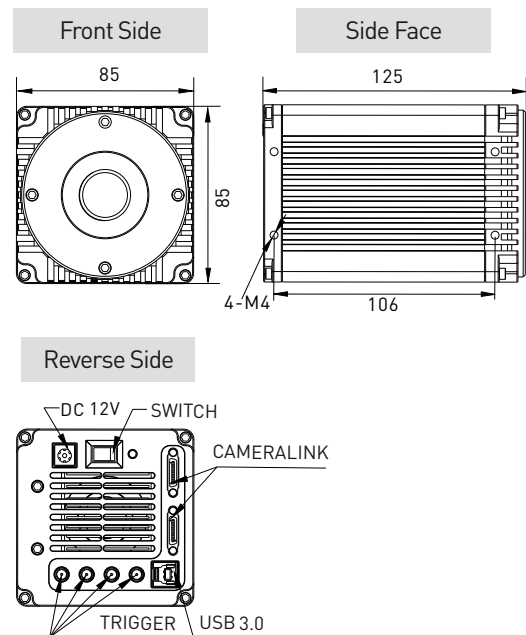

# Tucsen Photonics Co., Ltd.

Address: 5# Wanwushe Smart Industrial Park , No.2 Yangqi Branch Rd,  
Gaishan Town, Cangshan Area, Fuzhou, Fujian, PRC, China.  
Tel: + 86-591-28055080  
Website: [www.tucsen.com](http://www.tucsen.com)  
Email: [support@tucsen.com](mailto:support@tucsen.com)