

❖ **GO-5101-PMCL**
5.1-megapixel CMOS global shutter



- *5.1-megapixel 2/3" CMOS imager (global shutter)*
- *Up to 35.6 fps at full resolution*
- *3.45 μm square pixels*
- *Small size (29 x 29 x 41.5 mm, excluding lens mount)*
- *8/10-bit output in choice of monochrome or raw Bayer models*
- *Exposure control from 14 μs to 8 seconds in 1 μs steps*
- *2X binning for increased sensitivity (monochrome only)*
- *ROI mode for increasing frame rate and use of smaller optics*
- *Automatic Level Control (ALC) for dynamic lighting conditions*
- *Accepts power over Camera Link interface or separate 4-pin connector*
- *C-mount lens mount*

Specifications for GO-5101-PMCL

Go Series

Specifications	GO-5101-PMCL
Sensor	2/3" CMOS global shutter (IMX264)
System clock	74.25 MHz (for pulse generator)
Frame rate (Full frame)	35.6 frames/sec. @ 8-bit (continuous)
Active area	8.5 mm (h) x 7.09 mm (v), 11.1 mm diagonal
Cell size	3.45 μm (h) x 3.45 μm (v)
Active pixels	2464 (h) x 2056 (v)
Read-out modes	Full ROI: 2464 (h) x 2056 (v) up to 35.6 fps 2 lines to 2056 lines in 2-line steps, 96 to 2464 pixels wide in 16-pixel steps
Binning	1x2, 2x2, 2x1 (monochrome only)
EMVA 1288 Parameters	12-bit output format
Absolute sensitivity (mono)	3.54 p (λ = 525 nm)
Absolute sensitivity (color)	3.94 p (λ = 525 nm)
Maximum SNR (mono)	40.26 dB
Maximum SNR (color)	40.26 dB
Traditional SNR*	mono > 60 dB @ 10-bit (0 dB gain, non-linear) color > 60 dB @ 10-bit (0 dB gain, green, non-linear)
Video signal output	mono 8/10-bit monochrome color 8/10-bit raw Bayer (12-bit available in Video Process Bypass mode)
Gain control	Manual/auto 0 dB to +24 dB
White balance (GO-5101C)	Manual, one-push auto, or continuous (3000K to 9000K)
Gamma	0.45, 0.6, 1.0 or 256-point LUT
Synchronization	Internal
Video modes	Normal ROI, Trigger Sequencer, Command Sequencer
Trigger input	TTL, Camera Link (CC1), NAND (2), Software, Pulse Generator, User Output (2)
Trigger modes	Timed (EPS), Trigger Width, Sequencer
Electronic shutter	Timed: 14 μs to 8 sec (1 μs/step) Auto: 100 μs to 8 sec
Auto level control (ALC)	Shutter range from 100 μs to 8 sec. gain range from 0 dB to +24 dB Tracking speeds and max values adjustable
Pre-processing functions	Flat shading/color shading correction, blemish compensation (512 pixels)
Operating temperature	-5°C to +45°C
Storage temperature	-25°C to +60°C
Humidity	20 - 80% non-condensing
Vibration	10G (20 Hz to 200 Hz XYZ)
Shock	80 G
Regulations	CE (EN-61000-6-2, EN-61000-6-3), FCC Part 15 class B, RoHS/WEEE
Power	12V to 24V DC ± 10%. 2.88W typical @ 12V (12V ± 1V DC via PoCL)
Lens mount	C-mount
Dimensions (H x W x L)	29 mm x 29 mm x 41.5 mm (excl. lens mount)
Weight	46 g

Ordering Information	
GO-5101M-PMCL	Monochrome camera with Mini Camera Link
GO-5101C-PMCL	Color camera with Mini Camera Link

* Traditional SNR is based on random noise in a single frame, where EMVA SNR measurements consider more comprehensive noise sources and variance over time. For a more complete description, see the manual.

Dimensions

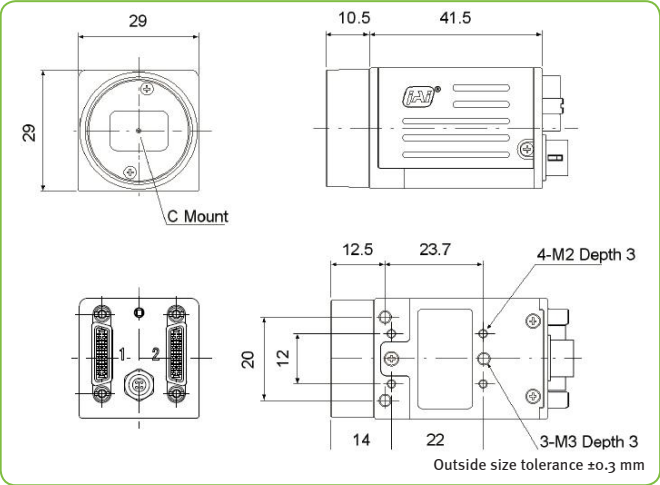

Connector pin-out

Mini-CL Interface Interface 1

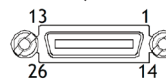

Pin	Signal	Function
1	26	Power +12V ± 1V DC in
13	14	GND Power return
2	15	-/+ TxOUT 0
3	16	-/+ TxOUT 1
4	17	-/+ TxOUT 2
5	18	-/+ TxClk
6	19	-/+ TxOUT 3
7	20	+/- RXD Serial in
8	21	-/+ TXD Serial out
9	22	CC1-/CC1+ Ext. trigger
10	23	CC2+/CC2- Reserved
11	24	CC3-/CC3+ Not used
12	25	CC4+/CC4- Not used

For Medium and Full implementations a second Mini-CL interface is provided. Video Channel 2 is on pin pairs (2,15), (3,16), (4,17), (5,18), and (6,19). Video Channel 3 is on pin pairs (8,21), (9,22), (10,23), (11,24), and (12,25). Consult manual for Specific bit depths and pin assignments.

DC In / Trigger



09-3111-81-04 (Binder)

Pin	Signal
1	+12V to +24V DC Input
2	TTL In (Line 4)
3	TTL Out (Line 1)
4	GND

Spectral Response

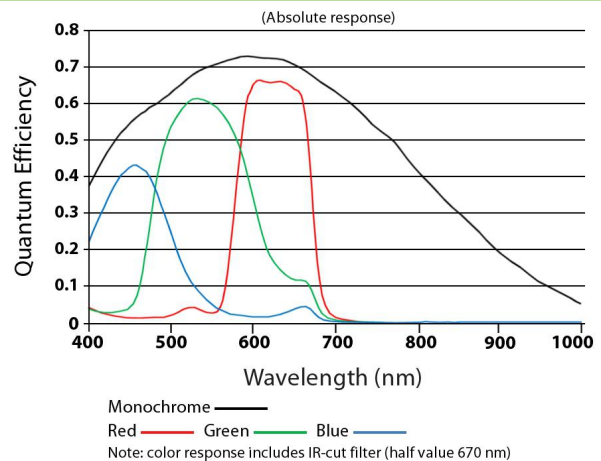

Europe, Middle East & Africa
Phone +45 4457 8888
Fax +45 4491 3252

Asia Pacific
Phone +81 45 440 0154
Fax +81 45 440 0166

Americas
Phone (Toll-Free) 1 800 445 5444
Phone +1 408 383 0300

Visit our web site on www.jai.com

See the possibilities

