

➤ **SP-5000-CXP4**
5-megapixel CMOS global shutter

CoaXPRESS[®]



- **Large format 5 MP CMOS imager (global shutter)**
- **Up to 250 fps at full resolution**
- **5.0 μm square pixels in a 5:4 aspect ratio**
- **60 dB linear dynamic range with up to 100 dB piece-wise HDR modes**
- **Analog and digital gain control for less quantized noise in low-light situations**
- **Exposure control from 10 μs (1/100,000) to 8 seconds in 1 μs steps**
- **2X binning for increased sensitivity (monochrome only)**
- **ROI modes for flexible readout, windowing, or increasing frame rate**
- **Monochrome or color models with built-in color interpolation on color model**
- **8/10/12-bit digital output over four-channel CoaXPRESS interface**
- **Accepts power via CoaXPRESS or separate 12-pin connector**
- **C-mount lens mount**
- **Automatic Level Control (ALC) for dynamic lighting conditions**
- **Programmable P-iris lens control or 3-axis control for operation of motorized lenses, pan/tilt heads, or other analog accessories**



Specifications for SP-5000-CXP4

Spark Series

Specifications	SP-5000-CXP4
Sensor	1" CMOS global shutter
Pixel clock	86.4 MHz
Frame rate, full frame	250 frames/sec. @ 8/10/12-bit, CXP-6x4
Active area	12.8 mm (h) x 10.2 mm (v), 16.39 mm diagonal
Cell size	5.0 μm (h) x 5.0 μm (v)
Active pixels	2560 (h) x 2048 (v)
Read-out modes	Full ROI 2560 (h) x 2048 (v) up to 250 fps Any start line, any height in 2 line steps, with X offset and width in 64 pixel steps
Binning	1x2, 2x1, 2x2 (monochrome only)
Color interpolation (SP-5000C)	24-bit RGB output at up to 53 fps
EMVA 1288 Parameters	10-bit output format
Absolute sensitivity (mono)	23.50 p (λ = 525 nm)
Absolute sensitivity (color)	36.08 p λ = 525 nm)
Maximum SNR (mono)	41.48 dB
Maximum SNR (color)	38.00 dB
Traditional SNR*	mono >55 dB (0 dB gain) color >53 dB (0 dB gain, green)
Video signal output	mono 8/10/12-bit monochrome color 8/10/12-bit Bayer or 24-bit RGB
Auto-iris lens video output	0.7Vp-p, with 0.3V horiz. sync
Gain	Manual/automatic 0 dB to +24 dB
White balance (SP-5000C)	Manual, one-push auto, or continuous (3000K to 9000K)
Gamma	0.45-1.0 (16 steps) or 256-point LUT
Synchronization	Internal
Trigger input	TTL, CXP, Pulse Generators (4), Software, NAND Out (2), GPIO
Trigger modes	EPS, PIV, Trigger Width, Timed RCT (with ALC), Sequence
Electronic shutter	Timed exposure 10 μs to 8 sec in 1 μs steps Auto shutter 1/250 to 1/100000 sec.
Auto Level Control (ALC)	Shutter range from 1/250 to 1/100000, gain range from 0 dB to +24 dB, auto iris control Tracking speeds and max values adjustable.
Pre-processing functions	Flat field correction, color shading correction (SP-5000C), blemish compensation (512 pixels)
3-axis control	Programmable control of motorized lenses, pan/tilt heads, and other analog accessories
Operating temperature	-45°C to +70°C†
Storage temperature	-45°C to +70°C
Humidity	20 - 80% non-condensing
Vibration	10 G (20Hz to 200Hz XYZ)
Shock	80 G
Regulations	CE (EN61000-6-2, EN61000-6-3), FCC Part 15 class B, RoHS/WEEE
Power	12V to 24V DC ± 10%. 7.8W typical (full frame @ 12V)
Lens mount	C-mount (fixed or adjustable)
Dimensions (H x W x L)	62 mm x 62 mm x 55.5 mm
Weight	215 g

Ordering Information

SP-5000M-CXP4	Monochrome camera with four-channel CoaXPress
SP-5000C-CXP4	Color camera with four-channel CoaXPress

Note: Add-CX to model number for adjustable c-mount.

*Traditional SNR is based on random noise in a single frame, where EMVA SNR measurements consider more comprehensive noise sources and variance over time. For a more complete description, see the manual.

†Reduced performance may occur when operating outside the standard range of -5°C to +45°C

Dimensions

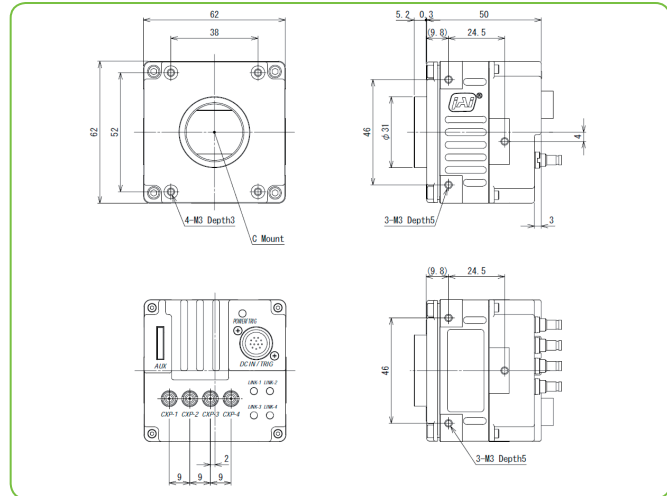

Connector pin-out

DC In / Trigger

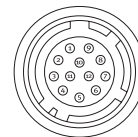

HIROSE HR10A-10R-12PB-01

Connector Pin-out	Pin	Description
1	GND	
2	+12V to +24V DC input	
3	GND	
4	NC	
5	Opto In-	
6	Opto In+	
7	Opto Out-	
8	Opto Out+	
9	TTL out 1	
10	TTL in 1	
11	+12V to +24V DC input	
12	GND	

CoaXPress Interface

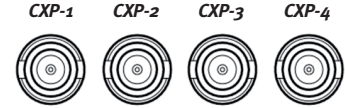

One-, two-, or four-channel output
Requires cable(s) with 75Ω
1.0/2.3 DIN-type connector
Supports up to 6.25 Gbps per channel
Power can be supplied on channel #1

Spectral Response

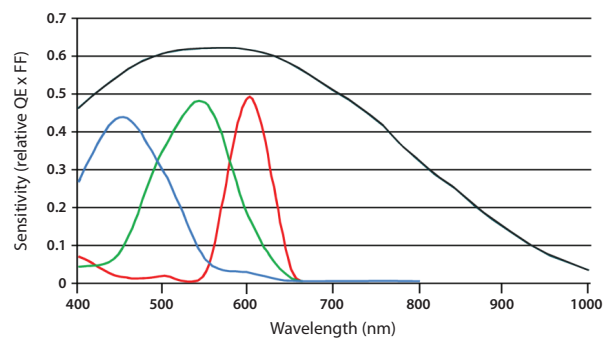

Note: Color response includes IR-cut filter.

Company and product names mentioned in this datasheet are trademarks or registered trademarks of their respective owners. JAI/JS cannot be held responsible for any technical or typographical errors and reserves the right to make changes to products and documentation without prior notification.

Europe, Middle East & Africa
Phone +45 4457 8888
Fax +45 4491 3252

Asia Pacific
Phone +81 45 440 0154
Fax +81 45 440 0166

Americas
Phone (Toll-Free) 1 800 445 5444
Phone +1 408 383 0300

Visit our web site on www.jai.com

See the possibilities