

❖ **SP-5000-CXP2**
5-megapixel CMOS global shutter



- **Large format 5 MP CMOS imager (global shutter)**
- **Up to 209 fps at full resolution over 2x CoaXPress interface**
- **5.0 μm square pixels in a 5:4 aspect ratio**
- **60 dB linear dynamic range with 100 dB piece-wise HDR mode**
- **Auto-scaling A/D front-end for improved dynamic range in low light applications**
- **On-chip 4-channel analog gain for individual R, G1, G2, + B control**
- **2X and 4X binning for increased sensitivity (monochrome only)**
- **ROI and decimation modes for flexible readout, windowing, or increasing frame rate**
– 419 fps at 1280 x 1024 pixels, 888 fps at 640 x 480 pixels
- **Monochrome or color models with raw Bayer or in-camera RGB/YUV interpolation**
- **Accepts power over CoaXPress or 12-pin connector for maximum application flexibility**
- **C-mount lens mount**
- **Automatic Level Control (ALC) for dynamic lighting conditions**
- **Programmable P-iris lens control or optional 3-axis DC-iris control for operation of motorized lenses, pan/tilt heads, or other analog accessories**



Specifications for SP-5000-CXP2

Spark Series

Specifications	SP-5000-CXP2
Sensor	1" CMOS global shutter
Pixel Clock	72 MHz
Frame rate, full frame	209 frames/sec.*
Active area	12.8 mm (h) x 10.2 mm (v)
Cell size	5.0 μm (h) x 5.0 μm (v)
Active pixels	2560 (h) x 2048 (v)
Horizontal output frequency	463.36 kHz
Read-out modes	Full 2560 (h) x 2048 (v) 209 fps (8-bit) ROI (mono) 2560 (h) x 2048 (v) 104 fps (10/12-bit) ROI (color) Any start line, any height, in 1 line steps, with X offset and width in 16 pixel steps
Binning	Any start line, any height, in 2L steps with X offset and width in 16 pixel steps 1x2, 2x1, 2x2 (monochrome only)
Sensitivity (SP-5000M)	X.X Lux (shutter off, max. gain, f1.4, 50% video)
Sensitivity (SP-5000C)	X.X Lux (shutter off, max. gain, f1.4, 50% green)
S/N ratio	mono >55 dB. (0 dB gain) color >53 dB. (0 dB gain, green)
Video signal output	mono 8/10/12-bit monochrome color 8/10/12-bit Bayer in-camera interpolation 24/30-bit RGB, YUV4:1:1, or YUV4:2:2
Auto-iris lens video output	0.7Vp-p, with 0.3V horiz. sync
Gain	Manual/automatic 0 dB to +24 dB
White balance (SP-5000C)	Manual, one-push auto, or continuous (3000K to 9000K)
Gamma	0.45-1.0 (16 steps) or 256-point LUT
Synchronization	Internal
Inputs/Outputs	GPIO in/out through Hirose 12-pin connector
Trigger input	Line4 (TTL in), Line7 (trigger packet)
Trigger modes	EPS, PIV, Trigger Width, RCT (with ALC)
Electronic shutter	Timed exposure 10 μs to 8 sec in 1 μs steps Auto shutter Continuous to 1/100,000 sec.
Auto level control (ALC)	Integrated shutter, gain, and auto iris control Tracking speeds and max values adjustable
Pre-processing functions	Flat field correction, color shading correction (SP-5000C), CMOS pattern correction, blemish compensation (>500 pixels)
3-axis control	Programmable control of motorized lenses, pan/tilt heads, and other analog accessories
Operating temperature	-5° C to +45° C
Storage temperature	-45° C to +70° C
Humidity	20 - 80% non-condensing
Vibration	10G (20 Hz to 200 Hz XYZ)
Shock	80 G
Regulations	CE (EN 61000-6-2, EN 61000-6-3), FCC part 15 class B, RoHS/WEEE
Power	12V to 24V DC ± 10%. 5.9W typical (full frame @ 12V)
Lens mount	C-mount
Dimensions (H x W x L)	62 mm x 62 mm x 55.5 mm
Weight	260 g

*Monochrome or raw Bayer. See table below for color interpolation

Color Interpolation (in-camera)

RGB	79 fps (24-bit), 63 fps (30-bit)
YUV	158 fps (4:1:1), 119 fps (4:2:2)

Ordering Information

SP-5000M-CXP2	Monochrome camera with CoaXPress 1x/2x
SP-5000C-CXP2	Color camera with CoaXPress 1x/2x

Dimensions

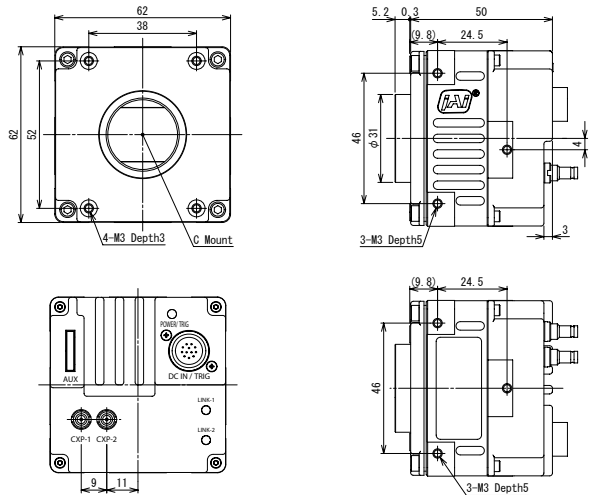

Connector pin-out

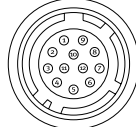
DC In / Trigger	Pin	Connector Pin-out	Pin
 HIROSE HR10A-10R-12PB-01	1	GND	7
	2	+12V to +24V DC input	8
	3	Opto in 2(-)*/GND	9
	4	Opto in 2(+)* / Auto iris lens	10
	5	Opto in 1(-)	11
	6	Opto in 1(+)	12
		* Pins 3 and 4 can be configured by internal switch selection	

Spectral Response

Monochrome

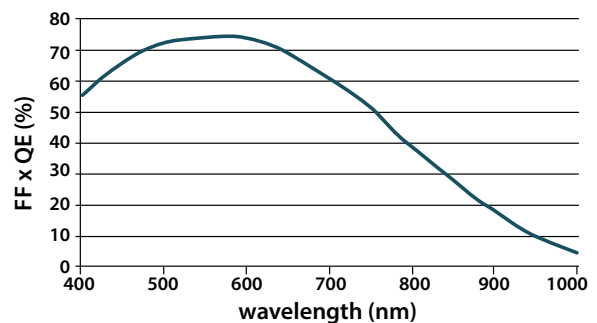

Color

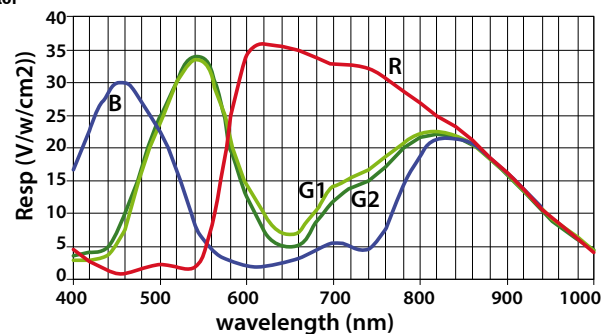

Company and product names mentioned in this datasheet are trademarks or registered trademarks of their respective owners. JAI-A-5 cannot be held responsible for any technical or typographical errors and reserves the right to make changes to products and documentation without prior notification.

Europe, Middle East & Africa
Phone +45 4457 8888
Fax +45 4491 3252

Asia Pacific
Phone +81 45 440 0154
Fax +81 45 440 0166

Americas
Phone (Toll-Free) 1 800 445 5444
Phone +1 408 383 0300



Visit our web site on www.jai.com

See the possibilities